

MSZ-GX12NL & MUZ-GX12NL  
12,000 BTU/H WALL-MOUNTED INDOOR UNIT  
12,000 BTU/H INVERTER HEAT PUMP OUTDOOR UNIT



Job Name:

System Reference:

Date:



INDOOR Unit ... MSZ-GX12NL

OUTDOOR Unit ... MUZ-GX12NL

#### INDOOR UNIT FEATURES

- Dual Barrier Coating: Dual Barrier Coating reduces the collection of contaminants like dust, fibers, smoke, and oil on the inner surface of the indoor unit.
- Swing Mode: An indoor unit with this capability can move air throughout the room like an oscillating fan.
- Econo Cool: Econo Cool is feature that temporarily adjusts the airflow to maintain comfort while using less energy.
- Quiet: Our indoor units offer whisper-quiet operation as low as 19 dB(A). Our outdoor units are design for ultra quiet operation.
- Horizontal Vane Control: Horizontal Vane Control allows the indoor unit vanes to be moved left right to provide even temperatures throughout a space.
- Wi-Fi Enabled: Wi-Fi enabled units pair with the Comfort app for complete control over temperature, fan speeds, modes, schedules, and more.

#### OUTDOOR UNIT FEATURES

- Inverter Driven Compressor: Inverter technology uses only the precise amount of energy needed to keep a space comfortable.
- Blue Fin Coating: Anti-corrosion coating that protects the outdoor heat exchanger against salt, sulfur, and other airborne contaminants that impact the efficiency and performance of the outdoor units.
- Seacoast Protection: Designed to protect against the corrosive effects of environments that are in close proximity to the sea.

**SPECIFICATIONS: MSZ-GX12NL & MUZ-GX12NL**

Cooling at 95F <sup>1</sup>	Maximum Capacity	Btu/h	14000
	Rated Capacity	Btu/h	12000
	Minimum Capacity	Btu/h	1300
	Maximum Power Input	W	1490
	Rated Power Input	W	900
	Moisture Removal	Pints/h	2.50
	Sensible Heat Factor		0.77
Heating at 47F <sup>2</sup>	Power Factor [208V / 230V]	%	93 / 93
	Maximum Capacity	Btu/h	18100
	Rated Capacity	Btu/h	14400
	Minimum Capacity	Btu/h	1500
	Maximum Power Input	W	1780
	Rated Power Input	W	1100
Heating at 17F <sup>3</sup>	Power Factor [208V / 230V]	%	95 / 95
	Maximum Capacity	Btu/h	12000
	Rated Capacity	Btu/h	9000
	Maximum Power Input	W	1670
Heating at 5F <sup>5</sup>	Rated Power Input	W	1000
	Maximum Capacity	Btu/h	10100
Heating at -5F <sup>7</sup>	Maximum Power Input	W	1640
Heating at -10F <sup>8</sup>	Maximum Capacity	Btu/h	7700
Efficiency	Maximum Capacity	Btu/h	6780
	SEER2		25.60
	EER2 <sup>1</sup>		13.35
	HSPF2 [IV]		10.70
	COP at 47°F <sup>2</sup>		3.84
	COP at 17°F at Maximum Capacity <sup>3</sup>		2.10
	COP at 5°F at Maximum Capacity <sup>5</sup>		1.80
	COP at -5°F at Maximum Capacity <sup>7</sup>		1.40
COP at -10°F at Maximum Capacity <sup>8</sup>		1.24	
Electrical	ENERGY STAR® Certified		Yes
	Voltage, Phase, Frequency	V AC / V AC , φ , Hz	208 / 230 , 1 , 60
	Guaranteed Voltage Range	V AC	187 - 253
	Voltage: Indoor - Outdoor, S1-S2	V AC	230 / 208
	Voltage: Indoor - Outdoor, S2-S3	V DC	24
	Short-circuit Current Rating [SCCR]	kA	5
	Recommended Fuse/Breaker Size (Outdoor)	A	15
Indoor Unit	Recommended Wire Size [Indoor - Outdoor]	AWG	14
	MCA	A	1
	Fan Motor Output	W	30
	Fan Motor Type		DC Motor
	Airflow Rate at Cooling, Dry	CFM	151 , 172 , 256 , 353 , 448
	Airflow Rate at Cooling, Wet	CFM	136 , 154 , 230 , 318 , 403
	Airflow Rate at Heating, Dry	CFM	151 , 172 , 256 , 353 , 448
	Sound Pressure Level [Cooling]	dB (A)	19 , 22 , 30 , 37 , 45
	Sound Pressure Level [Heating]	dB (A)	19 , 22 , 30 , 37 , 43
	Drain Pipe Size O.D.	inch [ mm ]	5/8 [ 15.88 ]
	Dual Barrier Coating on Heat Exchanger		Yes
	Dual Barrier Coating on Fan		Yes
	External Finish Color		Munsell 0.7PB 9.2/0.4
	Unit Dimensions (W x D x H)	inch x inch x inch [ mm x mm x mm ]	31-13/32 x 9-21/32 x 11-25/32 [ 798 x 245 x 299 ]
	Package Dimensions (W x D x H)	inch x inch x inch [ mm x mm x mm ]	34-1/4 x 14-1/4 x 12-3/4 [ 870 x 360 x 320 ]
	Unit Weight	lbs [ kg ]	23 [ 10.40 ]
	Package Weight	lbs [ kg ]	27 [ 12 ]
IDU Operating Temp. Range	Cooling Intake Air Temp [Maximum / Minimum]	deg F , deg F / deg F , deg F	90 , 73 / 67 , 57

**Notes**

<sup>1</sup>Cooling (Indoor // Outdoor) °F 80 DB, 67 WB // 95 DB, 75 WB - test

<sup>2</sup>Heating at 47°F (Indoor // Outdoor) °F 70 DB, 60 WB // 47 DB, 43 WB

<sup>3</sup>Heating at 17°F (Indoor // Outdoor) °F 70 DB, 60 WB // 17 DB, 15 WB

<sup>5</sup>Heating at 5°F (Indoor // Outdoor) °F 70 DB, 60 WB // 5 DB, 4 WB

<sup>7</sup>Heating at -5°F (Indoor // Outdoor) °F 70 DB, 60 WB // -5 DB, -6 WB

<sup>8</sup>Heating at -10°F (Indoor // Outdoor) °F 70 DB, 60 WB // -10 DB, -11 WB

\*Indoor/Outdoor Unit Operating Temperature Range (Cooling Air Temp [Maximum / Minimum]): • Applications should be restricted to comfort cooling only; equipment cooling applications are not recommended for low ambient temperature conditions.

\*\*Outdoor Unit Operating Temperature Range (Cooling Thermal Lock-out / Re-start Temperatures; Heating Thermal Lock-out / Re-start Temperatures): • System cuts out in heating mode and automatically restarts at these temperatures.

## SPECIFICATIONS: MSZ-GX12NL & MUZ-GX12NL

IDU Operating Temp. Range	Heating Intake Air Temp [Maximum / Minimum]	deg F	80 / 70
Outdoor Unit	MCA	A	12
	MOCP	A	15
	Fan Motor Full Load Amperage	A	0.71
	Fan Motor Output	W	55
	Airflow Rate Cooling	CFM	1152
	Airflow Rate Heating	CFM	1139
	Defrost Method		Reverse Cycle
	Coating on Heat Exchanger (Bluefin, Sea Coast)		Yes , Yes
	Sound Pressure Level, Cooling <sup>1</sup>	dB (A)	49
	Sound Pressure Level, Heating <sup>2</sup>	dB (A)	51
	Compressor Type		Twin Rotary
	Compressor Model		SRB092FQFMC
	Compressor Oil [Type // Charge]	// oz	RM68EH // 11.8
	External Finish Color		Munsell 3Y 7.8/1.1
	Base Pan Heater		Optional
	Unit Dimensions (W x D x H)	inch x inch x inch [ mm x mm x mm ]	31-1/2 x 11-1/4 x 21-5/8 [ 800 x 285 x 550 ]
	Package Dimensions (W x D x H)	inch x inch x inch [ mm x mm x mm ]	37 x 15 x 24-1/2 [ 940 x 380 x 630 ]
Unit Weight	lbs [ kg ]	77 [ 34.60 ]	
Package Weight	lbs [ kg ]	84 [ 38 ]	
ODU Operating Temp. Range	Cooling Intake Air Temp [Maximum / Minimum*]	F	115 / 14
	Cooling Thermal Lock-out / Re-start Temperatures**	F	-1 / 3
	Heating Intake Air Temp [Maximum / Minimum]	F , F / F , F	75 , 65 / -5 , -6
	Heating Thermal Lock-out / Re-start Temperatures**	F	-14 / -4
Refrigerant	Type		R454B
	Pre-Charged Refrigerant Amount	lbs . oz	2 , 0
	Maximum Pre-Charged Piping Length	ft [ m ]	25 [ 7.50 ]
	Additional Refrigerant Charge Per Additional Piping Length	oz/ft	0.22
Piping	Gas Pipe Size O.D. [Flared]	inch [ mm ]	3/8 [ 9.52 ]
	Liquid Pipe Size O.D. [Flared]	inch [ mm ]	1/4 [ 6.35 ]
	Maximum Piping Length	ft [ m ]	65 [ 20 ]
	Maximum Height Difference	ft [ m ]	40 [ 12 ]
	Maximum Number of Bends		10

### Notes

<sup>1</sup>Cooling (Indoor // Outdoor) °F 80 DB, 67 WB // 95 DB, 75 WB - test

<sup>2</sup>Heating at 47°F (Indoor // Outdoor) °F 70 DB, 60 WB // 47 DB, 43 WB

<sup>3</sup>Heating at 17°F (Indoor // Outdoor) °F 70 DB, 60 WB // 17 DB, 15 WB

<sup>5</sup>Heating at 5°F (Indoor // Outdoor) °F 70 DB, 60 WB // 5 DB, 4 WB

<sup>7</sup>Heating at -5°F (Indoor // Outdoor) °F 70 DB, 60 WB // -5 DB, -6 WB

<sup>8</sup>Heating at -10°F (Indoor // Outdoor) °F 70 DB, 60 WB // -10 DB, -11 WB

\*Indoor/Outdoor Unit Operating Temperature Range (Cooling Air Temp [Maximum / Minimum]): • Applications should be restricted to comfort cooling only; equipment cooling applications are not recommended for low ambient temperature conditions.

\*\*Outdoor Unit Operating Temperature Range (Cooling Thermal Lock-out / Re-start Temperatures; Heating Thermal Lock-out / Re-start Temperatures): • System cuts out in heating mode and automatically restarts at these temperatures.

## INDOOR UNIT ACCESSORIES: MSZ-GX12NL

Condensate	Refco Condensate Removal Pump with Wall Mount Enclosure 120-240V up to 120k BTU/h	<input type="checkbox"/>	GOBI-II
	Blue Diamond (MaxiBlue Advanced) Mini Condensate Pump w/ Reservoir & Sensor (110V) up to 48,000 BTU/H [recommended]	<input type="checkbox"/>	X87-711
	Blue Diamond Sensor Extension Cable 15 Ft	<input type="checkbox"/>	C13-103
	Blue Diamond MicroBlue Condensate Pump 115-230V up to 18k BTU/h	<input type="checkbox"/>	X86-003
	Sauermann Condensate Pump 120-230V up to 60k BTU/h	<input type="checkbox"/>	SI30-230
	Blue Diamond MegaBlue Condensate Pump with Reservoir Sensor 115-230V up to 170k BTU/h	<input type="checkbox"/>	X87-835
	Drain Pan Level Sensor/Control	<input type="checkbox"/>	SS610E
	Refco Condensate Pump 100-240V up to 120k BTU/h	<input type="checkbox"/>	COMBI
	Blue Diamond MicroBlue Condensate Pump with Fascia Kit 115-230V up to 18k BTU/h	<input type="checkbox"/>	X86-011
	Blue Diamond MaxiBlue Condensate Pump with Reservoir Sensor 115-230V up to 48k BTU/h	<input type="checkbox"/>	X88-721
Control Interface	Airzone Wired Blueface Controller White	<input type="checkbox"/>	AZZBSBLUEZEROCB
	M-Net I/O Control Interface for M-Series <sup>2</sup>	<input type="checkbox"/>	MAC-334IF-E
	Airzone Wired Blueface Controller Black	<input type="checkbox"/>	AZZBSBLUEZEROCN
	Airzone Wireless Lite Controller White	<input type="checkbox"/>	AZZBSLITERB
	IT Extender	<input type="checkbox"/>	PAC-WHS01IE-E
	Airzone Wireless Think Controller White	<input type="checkbox"/>	AZZBSTHINKRB
	Airzone Wireless Think Controller Black	<input type="checkbox"/>	AZZBSTHINKRN
	kumo station® for Comfort app	<input type="checkbox"/>	PAC-WHS01HC-E
	Thermostat Interface for 3rd Party Thermostats	<input type="checkbox"/>	PAC-US445CN-1
	Airzone Wireless Lite Controller Black	<input type="checkbox"/>	AZZBSLITERN
	Procon BACnet® and Modbus® Interface	<input type="checkbox"/>	PAC-UKPRC001-CN-1
Wireless Interface 2 for Comfrot app	<input type="checkbox"/>	PAC-USWHS002-WF-2	
Disconnect Switch	30A600VUL fits 2 X 4 utility box - Black	<input type="checkbox"/>	TAZ-MS303
	(30A/600V/UL) [fits 2" X 4" utility box] - White	<input type="checkbox"/>	TAZ-MS303W
Drain Hose	Flexible Mini-Split Drain Hose	<input type="checkbox"/>	DRX-16
Filter	Microparticle Filter	<input type="checkbox"/>	MAC-EMF515FT-E
	Electro Static Anti-allergy Enzyme Filter	<input type="checkbox"/>	MAC-2320FT-E
Lineset	50 x 1/4 x 50 3/8 Lineset Twin-Tube Insulation	<input type="checkbox"/>	MLS143812T-50
	30 x 1/4 x 30 3/8 Lineset Twin-Tube Insulation	<input type="checkbox"/>	MLS143812T-30
	65 x 1/4 x 65 3/8 Lineset Twin-Tube Insulation	<input type="checkbox"/>	MLS143812T-65
	15 x 1/4 x 15 3/8 Lineset Twin-Tube Insulation	<input type="checkbox"/>	MLS143812T-15
N/A		<input type="checkbox"/>	Unknown
Remote Sensor	Wireless temperature and humidity sensor for Comfort app	<input type="checkbox"/>	PAC-USWHS003-TH-1
	Remote Temperature Sensor for MFZ MLZ and MSZ models	<input type="checkbox"/>	M21EAA307
Terminal Signal Adapter	Backup Heat Relay Kit	<input type="checkbox"/>	CN24RELAY-KIT-CM3
Wired Remote Controller	Simple MA Remote Controller <sup>1</sup>	<input type="checkbox"/>	PAC-YT53CRAU-J
	Simple Direct Wired Remote Controller	<input type="checkbox"/>	PAC-SDW01RC-1
	Touch MA Remote Controller <sup>1</sup>	<input type="checkbox"/>	PAR-CT01MAU-SB
	Deluxe MA Wired Remote Controller <sup>1</sup>	<input type="checkbox"/>	PAR-42MAAUB
Wireless Remote Controller	Lockdown Bracket for Wireless Handheld Remote Controllers	<input type="checkbox"/>	RCMKP1CB
	Wireless RedLINK™ Remote Controller	<input type="checkbox"/>	MHK2
<b>Notes</b>			

## OUTDOOR UNIT ACCESSORIES: MUZ-GX12NL

Air Outlet Guide	Air Outlet Guide	<input type="checkbox"/>	MAC-881SG-E
Control/Service Tool	M- & P-Series Maintenance Tool Cable Set	<input type="checkbox"/>	M21EC0397
	Maintenance Tool Interface	<input type="checkbox"/>	PAC-USCMS-MN-1
Drain Socket	Drain Socket	<input type="checkbox"/>	MAC-871DS
Hail Guards	Hail Guard	<input type="checkbox"/>	HG-B4
Mini-Split Wire	14 Gauge 4 wire Armored MiniSplit Cable250 ft roll	<input type="checkbox"/>	SW144-250
	14 Gauge 4 wire Armored MiniSplit Cable50 ft roll	<input type="checkbox"/>	SW144-50
	14 Gauge 4 wire MiniSplit Cable50 ft roll	<input type="checkbox"/>	S144-50
	14 Gauge 4 wire MiniSplit Cable250 ft roll	<input type="checkbox"/>	S144-250
Mounting Pad	Condensing Unit Mounting Pad 16 x 36 x 3	<input type="checkbox"/>	ULTRILITE1
Optional Defrost Heater	Base Heater	<input type="checkbox"/>	MAC-650BH-U
Snow/Rain Diverter	SnowRain Diverter	<input type="checkbox"/>	SRD-1
Stand	Outdoor Unit 3-14 inch Mounting Base Pair - Plastic	<input type="checkbox"/>	DSD-400P
	Condenser Wall Bracket	<input type="checkbox"/>	QSWB2000M-1
	Condenser Wall Bracket - Stainless Steel Finish	<input type="checkbox"/>	QSWBSS
	24 Single Fan Stand	<input type="checkbox"/>	QSMS2401M
	Outdoor Unit Stand 12 High	<input type="checkbox"/>	QSMS1201M
	18 Single Fan Stand	<input type="checkbox"/>	QSMS1801M
<b>Notes</b>			

# INDOOR UNIT DIMENSIONS: MSZ-GX12NL

**MSZ-GX06NL MSZ-GX09NL MSZ-GX12NL MSZ-GX15NL**  
**MSY-GX09NL MSY-GX12NL MSY-GX15NL**

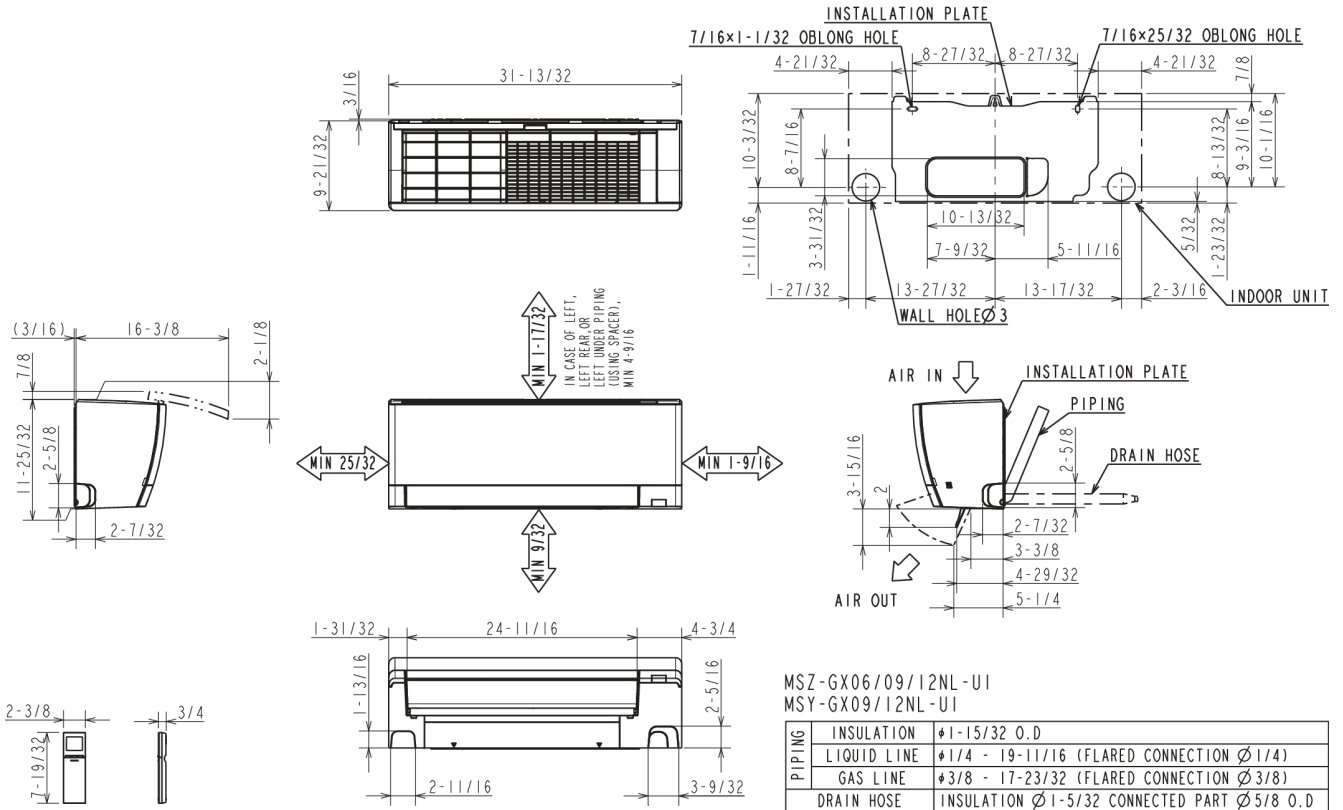

MSZ-GX06/09/12NL-UI  
 MSY-GX09/12NL-UI

PIPING	INSULATION	Ø1-15/32 O.D
	LIQUID LINE	Ø1/4 - 19-11/16 (FLARED CONNECTION Ø1/4)
	GAS LINE	Ø3/8 - 17-23/32 (FLARED CONNECTION Ø3/8)
	DRAIN HOSE	INSULATION Ø1-5/32 CONNECTED PART Ø5/8 O.D

MSZ-GX15NL-UI  
 MSY-GX15NL-UI

PIPING	INSULATION	Ø1-15/32 O.D
	LIQUID LINE	Ø1/4 - 19-11/16 (FLARED CONNECTION Ø1/4)
	GAS LINE	Ø3/8 - 17-23/32 (FLARED CONNECTION Ø1/2)
	DRAIN HOSE	INSULATION Ø1-5/32 CONNECTED PART Ø5/8 O.D

# OUTDOOR UNIT DIMENSIONS: MUZ-GX12NL

- MUZ-GX09NL-U1
- MUZ-GX12NL-U1
- MUZ-GX15NL-U1
- MUZ-GX09NLHZ-U1
- MUZ-GX12NLHZ-U1
- MUZ-GX15NLHZ-U1
- MUY-GX09NL-U1
- MUY-GX12NL-U1
- MUY-GX15NL-U1

## REQUIRED SPACE

\*1 4 in. (100 mm) or more when front and sides of the unit are clear

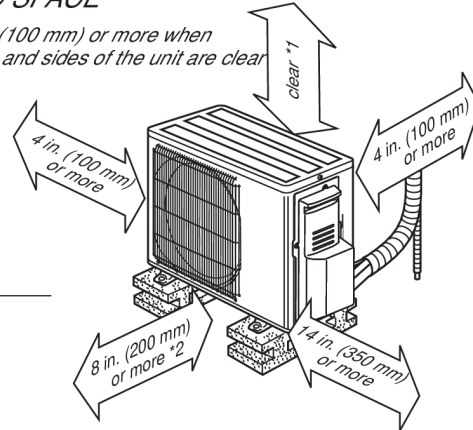

\*2 When any 2 sides of left, right and rear of the unit are clear

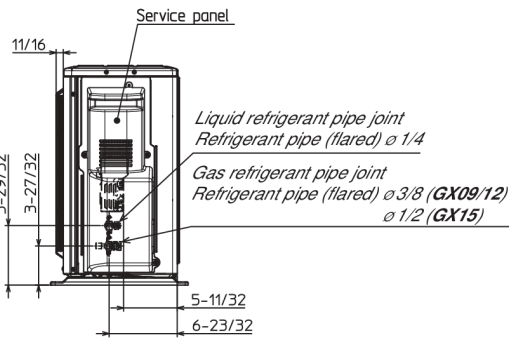
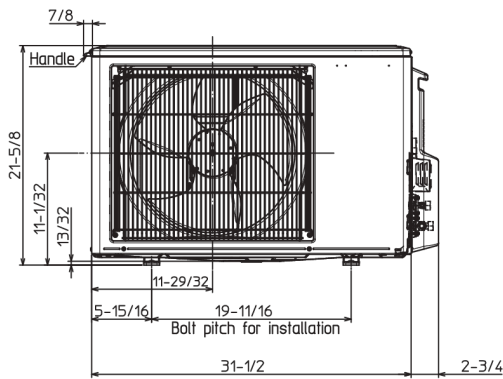
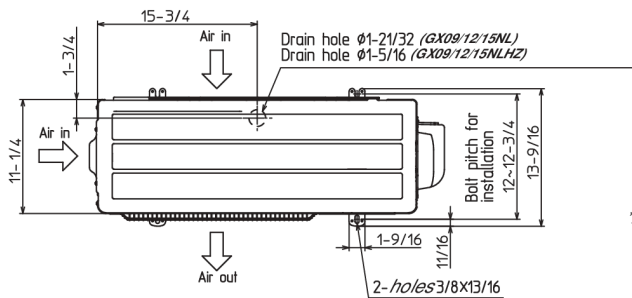

### MUZ-GX09/12NL MUZ-GX09/12NLHZ MUY-GX09/12NL

REFRIGERANT PIPE JOINT	LIQUID REFRIGERANT PIPE	FLARED 1/4"
	GAS REFRIGERANT PIPE	FLARED 3/8"

### MUZ-GX15NL MUZ-GX15NLHZ MUY-GX15NL

REFRIGERANT PIPE JOINT	LIQUID REFRIGERANT PIPE	FLARED 1/4"
	GAS REFRIGERANT PIPE	FLARED 1/2"

1340 Satellite Boulevard Suwanee, GA 30024  
Toll Free: 800-433-4822 · mitsubishicomfort.com

METUS\_2026-04\_PROPIN

