

CAPEA SERIES VERTICAL CASED COIL INSTALLATION INSTRUCTIONS

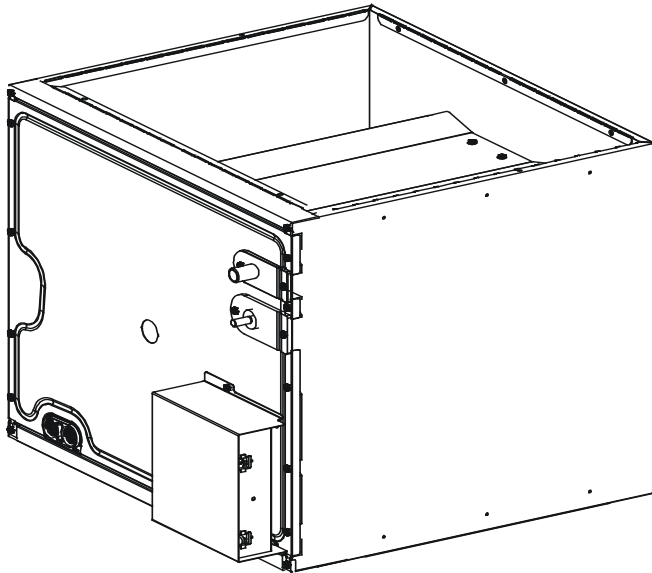

 **RECOGNIZE THIS SYMBOL AS A SAFETY PRECAUTION.**



WARNING: FLAMMABLE MATERIALS

DO NOT USE MEANS TO ACCELERATE THE DEFROSTING PROCESS OR TO CLEAN, OTHER THAN THOSE RECOMMENDED BY THE MANUFACTURER. THE APPLIANCE SHALL BE STORED IN A ROOM WITHOUT CONTINUOUSLY OPERATING IGNITION SOURCES (FOR EXAMPLE: OPEN FLAMES, AN OPERATING GAS APPLIANCE OR AN OPERATING ELECTRIC HEATER. DO NOT PIERCE OR BURN. BE AWARE THAT REFRIGERANTS MAY NOT CONTAIN AN ODOR.



WARNING

DO NOT BYPASS SAFETY DEVICES.



WARNING

ONLY PERSONNEL THAT HAVE BEEN TRAINED TO INSTALL, ADJUST, SERVICE, MAINTENANCE OR REPAIR (HEREINAFTER, "SERVICE") THE EQUIPMENT SPECIFIED IN THIS MANUAL SHOULD SERVICE THE EQUIPMENT.

THIS EQUIPMENT IS NOT INTENDED FOR USE BY PERSONS (INCLUDING CHILDREN) WITH REDUCED PHYSICAL, SENSORY OR MENTAL CAPABILITIES, OR LACK OF EXPERIENCE AND KNOWLEDGE, UNLESS THEY HAVE BEEN GIVEN SUPERVISION OR INSTRUCTION CONCERNING USE OF THE APPLIANCE BY A PERSON RESPONSIBLE FOR THEIR SAFETY.

CHILDREN SHOULD BE SUPERVISED TO ENSURE THAT THEY DO NOT PLAY WITH THE EQUIPMENT.

THE MANUFACTURER WILL NOT BE RESPONSIBLE FOR ANY INJURY OR PROPERTY DAMAGE ARISING FROM IMPROPER SUPERVISION, SERVICE OR SERVICE PROCEDURES. IF YOU SERVICE THIS UNIT, YOU ASSUME RESPONSIBILITY FOR ANY INJURY OR PROPERTY DAMAGE WHICH MAY RESULT. IN ADDITION, IN JURISDICTIONS THAT REQUIRE ONE OR MORE LICENSES TO SERVICE THE EQUIPMENT SPECIFIED IN THIS MANUAL, ONLY LICENSED PERSONNEL SHOULD SERVICE THE EQUIPMENT. IMPROPER SUPERVISION, INSTALLATION, ADJUSTMENT, SERVICING, MAINTENANCE OR REPAIR OF THE EQUIPMENT SPECIFIED IN THIS MANUAL, OR ATTEMPTING TO INSTALL, ADJUST, SERVICE OR REPAIR THE EQUIPMENT SPECIFIED IN THIS MANUAL WITHOUT PROPER SUPERVISION OR TRAINING MAY RESULT IN PRODUCT DAMAGE, PROPERTY DAMAGE, PERSONAL INJURY OR DEATH.



WARNING

IF ANY HOT WORK IS TO BE CONDUCTED ON THE REFRIGERATING EQUIPMENT OR ANY ASSOCIATED PARTS, APPROPRIATE FIRE EXTINGUISHING EQUIPMENT SHALL BE AVAILABLE ON HAND. HAVE A DRY POWDER OR CO₂ FIRE EXTINGUISHER ADJACENT TO THE CHARGING AREA.

ENSURE THAT THE AREA IS IN THE OPEN OR THAT IT IS ADEQUATELY VENTILATED BEFORE BREAKING INTO THE SYSTEM OR CONDUCTING ANY HOT WORK. A DEGREE OF VENTILATION SHALL CONTINUE DURING THE PERIOD THAT THE WORK IS CARRIED OUT. THE VENTILATION SHOULD SAFELY DISPERSE ANY RELEASED REFRIGERANT AND PREFERABLY EXPEL IT EXTERNALLY INTO THE ATMOSPHERE.

Our continuing commitment to quality products may mean a change in specifications without notice
© 2024 **DAIKIN COMFORT TECHNOLOGIES MANUFACTURING, L.P.**
19001 Kermier Rd., Waller, TX 77484
www.daikincomfort.com



is a registered trademark of Maytag Corporation or its related companies and is used under license. All rights reserved.



TABLE OF CONTENTS

1	Important Safety Instructions.....	2
2	Shipping Inspection.....	4
	2.1 Parts.....	4
	2.2 Handling.....	4
3	Codes & Regulations.....	4
4	Replacement Parts.....	4
5	Pre-Installation Considerations.....	4
	5.1 Preparation.....	5
	5.2 System Matches.....	6
	5.3 Clearances.....	6
	5.4 Access.....	6
6	Application Information.....	6
	6.1 Filler Plates.....	7
	6.2 Insulation Kit.....	7
	6.3 Down Flow Kit (For CAPEA4830C, D & CAPEA6030C, D).....	8
7	Return Ductwork.....	8
8	Refrigerant Piping Work.....	8
	8.1 Tubing Size/Length.....	9
	8.2 Cut Off The Spin Closure.....	9
	8.3 Disconnect Internal Control Wiring.....	10
	8.4 Connect Piping.....	10
	8.5 Re-assemble the Coil and Controls.....	11
9	Sealing Along The Panel Gap.....	12
10	Drain Piping Work.....	12
11	Electrical Wiring Work.....	14
	11.1 General Instructions.....	14
	11.2 Wiring Sizing.....	15
	11.3 Safety Device.....	15
	11.4 Transformer Installation.....	15
	11.5 How To Install The Transformer.....	15
	11.5.1A Installation Bracket - "A".....	16
	11.5.1B Installation Bracket - "B".....	16
	11.6 Wiring Transformer and PCB.....	17
	11.7 Sensor and Accessory Wiring.....	18
12	Fully Communicating System.....	19
	12.1 Overview.....	19
	12.2 Wire Harness Instructions.....	19
	12.3 Thermostat Wiring.....	19
	12.4 Two-Wire Outdoor and Four-Wire Indoor Wiring.....	20
	12.5 Airflow Trim.....	20
13	Miscellaneous Start-Up Checklist.....	20
14	Troubleshooting.....	21
	14.1 Electrostatic Discharge (ESD) Precautions.....	21
	14.2 Diagnostic Chart.....	21
	14.3 Fault Recall.....	21
	14.4 Network Troubleshooting.....	21
	14.5 System Troubleshooting.....	21
	Communications Troubleshooting Chart.....	22
	Troubleshooting.....	23
7	Segment LED Codes.....	24
	Setting the Mode Display.....	25
	Wiring Diagram.....	28
	Cased Coil Homeowners Routing	
	Maintenance Recommendations.....	29
	Start-Up Checklist.....	31

1 IMPORTANT SAFETY INSTRUCTIONS

The following symbols and labels are used throughout this manual to indicate immediate or potential safety hazards. It is the owner's and installer's responsibility to read and comply with all safety information and instructions accompanying these symbols. Failure to heed safety information increases the risk of personal injury, property damage, and/or product damage.

NOTICE: THIS PRODUCT CONTAINS ELECTRONIC COMPONENTS WHICH REQUIRE A DEFINITE GROUND. PROVISIONS ARE MADE FOR CONNECTION OF THE GROUND. A DEDICATED GROUND FROM THE MAIN POWER SUPPLY OR AN EARTH GROUND MUST BE PROVIDED.



WARNING

HIGH VOLTAGE

DISCONNECT ALL POWER BEFORE SERVICING OR INSTALLING THIS UNIT. MULTIPLE POWER SOURCES MAY BE PRESENT. FAILURE TO DO SO MAY CAUSE PROPERTY DAMAGE, PERSONAL INJURY OR DEATH.



WARNING

TO PREVENT THE RISK OF PROPERTY DAMAGE, PERSONAL INJURY, OR DEATH, DO NOT STORE COMBUSTIBLE MATERIALS OR USE GASOLINE OR OTHER FLAMMABLE LIQUIDS OR VAPORS IN THE VICINITY OF THIS UNIT.



WARNING

DO NOT CONNECT TO OR USE ANY DEVICE THAT IS NOT CERTIFIED BY THE MANUFACTURER FOR USE WITH THIS UNIT. SERIOUS PROPERTY DAMAGE, PERSONAL INJURY, REDUCED UNIT PERFORMANCE AND/OR HAZARDOUS CONDITIONS MAY RESULT FROM THE USE OF SUCH NON-APPROVED DEVICES.



WARNING

TO AVOID PROPERTY DAMAGE, PERSONAL INJURY OR DEATH DUE TO ELECTRICAL SHOCK, THIS UNIT MUST HAVE AN UNINTERRUPTED, UNBROKEN ELECTRICAL GROUND. THE ELECTRICAL GROUND CIRCUIT MAY CONSIST OF AN APPROPRIATELY SIZED ELECTRICAL WIRE CONNECTING THE GROUND LUG IN THE UNIT CONTROL BOX TO THE BUILDING ELECTRICAL SERVICE PANEL. OTHER METHODS OF GROUNDING ARE PERMITTED IF PERFORMED IN ACCORDANCE WITH THE NATIONAL ELECTRIC CODE (NEC)/ AMERICAN NATIONAL STANDARDS INSTITUTE (ANSI)/ NATIONAL FIRE PROTECTION ASSOCIATION (NFPA) 70 AND LOCAL/STATE CODES. IN CANADA, ELECTRICAL GROUNDING IS TO BE IN ACCORDANCE WITH THE CANADIAN ELECTRIC CODE (CSA) C22.1.



WARNING

THIS PRODUCT IS FACTORY-SHIPED FOR USE WITH 24VAC/1 PHASE/60HZ ELECTRICAL POWER SUPPLY. DO NOT CONFIGURE THIS CASED COIL TO OPERATE WITH ANY OTHER POWER SUPPLY.



WARNING

WHEN INSTALLING OR SERVICING THIS EQUIPMENT, SAFETY CLOTHING, INCLUDING HAND AND EYE PROTECTION, IS STRONGLY RECOMMENDED. IF INSTALLING IN AN AREA THAT HAS SPECIAL REQUIREMENTS (HARD HATS, ETC.), OBSERVE THESE REQUIREMENTS.



WARNING

FAILURE TO PROPERLY RECONNECT SENSOR WIRES MAY RESULT IN ERROR CODES AND THE UNIT NOT OPERATING.



DANGER PELIGRO

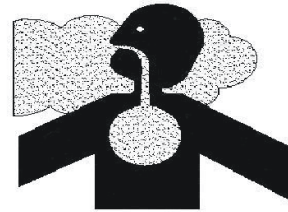

CARBON MONOXIDE POISONING HAZARD

Special Warning for Installation of Furnace or Air Handling Units in Enclosed Areas such as Garages, Utility Rooms or Parking Areas

Carbon monoxide producing devices (such as an automobile, space heater, gas water heater, etc.) should not be operated in enclosed areas such as unventilated garages, utility rooms or parking areas because of the danger of carbon monoxide (CO) poisoning resulting from the exhaust emissions. If a furnace or air handler is installed in an enclosed area such as a garage, utility room or parking area and a carbon monoxide producing device is operated therein, there must be adequate, direct outside ventilation.

This ventilation is necessary to avoid the danger of CO poisoning which can occur if a carbon monoxide producing device continues to operate in the enclosed area. Carbon monoxide emissions can be (re)circulated throughout the structure if the furnace or air handler is operating in any mode.

CO can cause serious illness including permanent brain damage or death.

B10259-216

RIESGO DE INTOXICACIÓN POR MONÓXIDO DE CARBONO

Advertencia especial para la instalación de calentadores ó manejadoras de aire en áreas cerradas como estacionamientos ó cuartos de servicio.

Los equipos ó aparatos que producen monóxido de carbono (tal como automóvil, calentador de gas, calentador de agua por medio de gas, etc) no deben ser operados en áreas cerradas debido al riesgo de envenenamiento por monóxido de carbono (CO) que resulta de las emisiones de gases de combustión. Si el equipo ó aparato se opera en dichas áreas, debe existir una adecuada ventilación directa al exterior.

Esta ventilación es necesaria para evitar el peligro de envenenamiento por CO, que puede ocurrir si un dispositivo que produce monóxido de carbono sigue operando en el lugar cerrado.

Las emisiones de monóxido de carbono pueden circular a través del aparato cuando se opera en cualquier modo.

El monóxido de carbono puede causar enfermedades severas como daño cerebral permanente ó muerte.

B10259-216

RISQUE D'EMPOISONNEMENT AU MONOXYDE DE CARBONE

Avvertissement special au sujet de l'installation d'appareils de chauffage ou de traitement d'air dans des endroits clos, tels les garages, les locaux d'entretien et les stationnements.

Evitez de mettre en marche les appareils produisant du monoxyde de carbone (tels que les automobile, les appareils de chauffage autonome, etc.) dans des endroits non ventilés tels que les d'empoisonnement au monoxyde de carbone. Si vous devez faire fonctionner ces appareils dans un endroit clos, assurez-vous qu'il y ait une ventilation directe provenant de l'exterieur.

Cette ventilation est nécessaire pour éviter le danger d'intoxication au CO pouvant survenir si un appareil produisant du monoxyde de carbone continue de fonctionner au sein de la zone confinée.

Les émissions de monoxyde de carbone peuvent être recirculés dans les endroits clos, si l'appareil de chauffage ou de traitement d'air sont en marche.

Le monoxyde de carbone peut causer des maladies graves telles que des dommages permanents au cerveau et même la mort.

B10259-216

2 SHIPPING INSPECTION

Upon receiving the product, inspect the unit for shipping damage. Shipping damage and subsequent investigation is the responsibility of the carrier. Verify the model number, specifications, electrical characteristics and accessories are correct prior to installation. The distributor or manufacturer will not accept claims from dealers for transportation damage or installation of incorrectly shipped units.

2.1 Parts

Also inspect the unit to verify all required components are present and intact. Report any missing components immediately to the distributor. Use only factory authorized replacement parts (see Section 4). Make sure to include the full product model number and serial number when reporting and/or obtaining service parts.

Transformer Installation Components

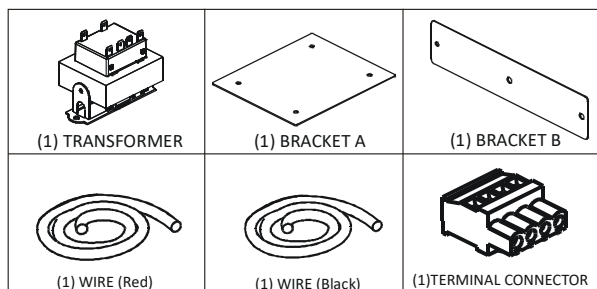

Literature Bag Components

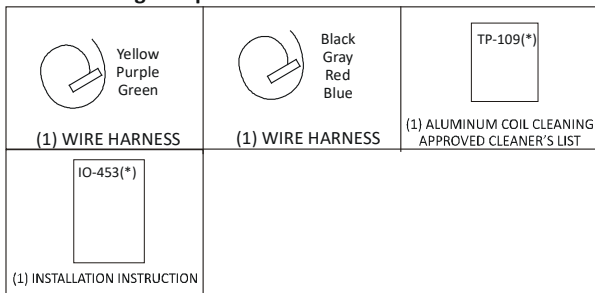

2.2 Handling

Use caution when handling the unit. Do not carry unit with hooks or sharp objects. The preferred method of carrying the unit after arrival at the job site is by two-wheel hand truck from the back or sides or by hand carrying at the cabinet corners. Take proper precautions when carrying/handling unit to avoid any damage to the piping.

3 CODES & REGULATIONS

This product is designed and manufactured to comply with applicable national codes. The Product shall be installed in accordance with national wiring regulations. Installation in accordance with such codes and/or prevailing local codes/regulations is the responsibility of the installer. Compliance with natural gas regulations shall be observed. The manufacturer assumes no responsibility for equipment installed in violation of any codes or regulations.

The United States Environmental Protection Agency (EPA) has issued various regulations regarding the introduction and disposal of refrigerants. Failure to follow these regulations may harm the environment and can lead to the imposition of substantial fines. Should you have any questions please contact the local office of the EPA and/or refer to the EPA's website www.epa.gov.

4 REPLACEMENT PARTS

When reporting shortages or damages, or ordering repair parts, give the complete product model and serial numbers as stamped on the product.

Replacement parts for this product are available through your contractor or local distributor. Your nearest distributor can be located online at www.daikincomfort.com or by contacting:

HOMEOWNER SUPPORT
 DAIKIN COMFORT TECHNOLOGIES
 MANUFACTURING, L.P.
 19001 KERMIER ROAD,
 WALLER, TX 77484
 855-770-5678

The appliance shall be installed in accordance with national wiring regulations. This product was tested at an external static pressure up to 0.6 WC. None of the components in this product line are designed or approved to be suitable for outdoor use.

5 PRE-INSTALLATION CONSIDERATIONS

The R-32 Sensor must be installed and powered for service. Ensure that the grommet is installed through the access panel knockout hole. Sensor bracket assemblies are shipped with two zip ties, one of which is designed for strain relief. This zip tie must be kept attached to bracket and wiring. Follow routing diagram as shown in figure 25 or 26 depending on orientation of install. This wiring is intended to be passed through the access hole of the furnace. If a hole must be cut into the furnace, ensure that the wiring is well protected from mechanical damage and that the hole is free from burrs or sharp edges. Utilize a protective coating for all exposed metallic edges.

This appliance is equipped with a leak detection device which must be wired through the A2L Connector on the furnace PCB or Non-A2L Furnace Integration Kit.

Scenario 1: A2L Certified Function on Daikin Family Furnace PCB.

The control board mitigation mode is set to 'ON' by default. The leak detection device must be installed to the port labeled for A2L input. If this port is not available on the board, then you must follow instructions in Scenario 2.

Verify that the A2L function (this is required for R-32 integration) is enabled on the furnace board PCB. Refer to the furnace IO for further instruction on how to toggle this function from disabled to enabled. The A2L verification step as described on the furnace IO must be completed before the unit is commissioned. If the test is not successful, call 1-855-DAIKIN1, option 3, for further assistance.

Scenario 2: NO A2L function on furnace PCB.

The leak detection device must be wired directly to the Non-A2L furnace integration kit board of an approved communicating Furnace. Utilize the AUX port on the parent PCB to wire in the Non-A2L Furnace Integration Kit and follow instructions in the related IO-7021 installation manual for mounting.

If additional charge is required, you must contact Daikin Comfort's Homeowner Support Line.

5.1 Preparation

Keep this document with the unit. Carefully read all instructions for the installation prior to installing product. Make sure each step or procedure is understood and any special considerations are taken into account before starting installation. Assemble all tools, hardware and supplies needed to complete the installation. Some items may need to be purchased locally. Make sure everything needed to install the product is on hand before starting.

The Indoor equipment mitigation requirements are calculated at sea level. For higher altitudes adjust the minimum room area specified on the Serial Plate by the corresponding altitude adjustment factor shown below. Table 1 is provided as a reference.

Adjusted room area ($A_{min\ adj}$) is the product of the minimum room area specified in the serial plate and the adjustment factor AF, as shown in the below formula

$$A_{min\ adj} = A_{min} (\text{serial plate}) * AF$$

Height in meters	Height in feet	Altitude Adjustment Factor (AF)
At sea level	At sea level	1.00
1-200	1-660	1.02
200-400	660-1320	1.03
400-600	1320-1970	1.05
600-800	1970-2630	1.07
800-1000	2630-3290	1.09
1000-1200	3290-3940	1.11
1200-1400	3940-4600	1.13
1400-1600	4600-5250	1.15
1600-1800	5250-5910	1.17
1800-2000	5910-6570	1.19
2000-2200	6570-7220	1.21
2200-2400	7220-7880	1.24
2400-2600	7880-8540	1.26
2600-2800	8540-9190	1.29
2800-3000	9190-9850	1.31
3000-3200	9850-10500	1.34

Table 1

Vertical Cased Coil Mitigation Chart

Cased Coil Mitigation Chart						
Model	Maximum Total System Refrigerant Charge (oz)	Maximum Total System Refrigerant Charge (kg)	Minimum Air Conditioned Room Area (m²)	Minimum Air Conditioned Room Area (ft²)	Minimum Mitigation Airflow (m³/hr)	Minimum Mitigation Airflow (CFM)
2.0T Match-up	132	3.74	11.12	120	366.89	216
2.5T Match-up	131	3.73	11.08	119	365.49	215
3.0T Match-up	138	3.93	11.66	126	384.93	227
4.0T Match-up	155	4.39	13.05	140	430.73	254
5.0T Match-up	185	5.26	15.62	168	515.55	303

Table 2

It is the installer's responsibility to verify that actuation of mitigation procedures are operational with minimum required airflow according to the chart.

5.2 System Matches

The entire system (combination of indoor and outdoor sections) must be manufacturer approved and Air-Conditioning, Heating, and Refrigeration Institute (AHRI) listed.

NOTE: Installation of unmatched systems is not permitted. Damage or repairs due to installation of unmatched systems is not covered under the warranty.

5.3 Clearances

The unit horizontal clearance from a surface may be 0" from walls and 1" from other units. However, service clearance must take precedence. A minimum of 24" in front of the unit for service clearance is required. Additional clearance on one side or top will be required for electrical wiring connections. Consult all appropriate regulatory codes prior to determining final clearances. In installations that may lead to physical damage (i.e. a garage) it is advised to install a protective barrier to prevent such damage. Always install units such that a positive slope in condensate line (1/4" per foot) is allowed.

Further, any joints made in the installation between parts of the refrigerating system must be accessible for maintenance.

NOTE: Furnace application requires that the installer MUST review and strictly follow ALL furnace installation clearance guidelines. Failure to do so may result in property/equipment damage, personal injury or death.

CONSULT ALL APPROPRIATE REGULATORY CODES WHEN DETERMINING FINAL CLEARANCES

5.4 Access

This unit should be installed in a manner so that it is not accessible to the public.

	WARNING: FLAMMABLE MATERIALS
WHEN INSTALLED IN A ROOM WITH AN AREA LESS THAN THAT OUTLINED IN TABLE 2, THAT ROOM SHALL BE WITHOUT CONTINUOUSLY OPERATING OPEN FLAMES (FOR EXAMPLE AN OPERATING GAS APPLIANCE) OR OTHER POTENTIAL IGNITION SOURCES (FOR EXAMPLE AN OPERATING ELECTRIC HEATER, HOT SURFACE).	

6 APPLICATION INFORMATION

Coils are designed for indoor installation only and must be installed downstream (discharge air) of the furnace and upstream (return air) of the modular blower. This product may be installed in upflow or downflow orientations.

If the unit is in an unconditioned area with high ambient temperature and/or high humidity, the coil may be subject to nuisance sweating of the casing. On these installations, a wrap of 2" fiberglass insulations with a vapor barrier is recommended. Do not cover warning labels and serial plate.

	WARNING
AUXILIARY DEVICES WHICH MAY BE A POTENTIAL IGNITION SOURCE ARE NOT TO BE INSTALLED IN THE DUCT WORK. SUCH POTENTIAL IGNITION SOURCES INCLUDE HOT SURFACES WITH A TEMPERATURE EXCEEDING 650°C AND ELECTRIC SWITCHING DEVICES. FOR EXAMPLE, ELECTRONIC AIR FILTERS ARE A POTENTIAL IGNITION SOURCE.	

	WARNING
ONLY AUXILIARY DEVICES APPROVED BY THE APPLIANCE MANUFACTURER OR DECLARED SUITABLE WITH THE REFRIGERANT SHALL BE INSTALLED IN CONNECTING DUCTWORK. IF AN EXISTING DEVICE IS NOT APPROVED BY THE APPLIANCE MANUFACTURER FOR USE WITH THE REFRIGERANT, THE DEVICE MUST BE REMOVED OR DISCONNECTED.	

	CAUTION
CHECK HORIZONTALITY LEVEL OF THE UNIT WITH SPIRIT LEVEL. DON'T TILT THE UNIT DOWN THAT MAKES IT DIFFICULT TO DRAIN EVEN THOUGH THE LEVEL IS WITHIN CRITERIA OF SPIRIT LEVEL. SEE FIGURE 1. SUCH TILTED UNITS MAY CAUSE WATER LEAKS.	

A coil installed with a furnace may be the same width as the furnace or may be one size larger than the furnace but cannot be smaller than the furnace. EXAMPLE: A "C" width coil may be installed with a "B" or a "C" width furnace.

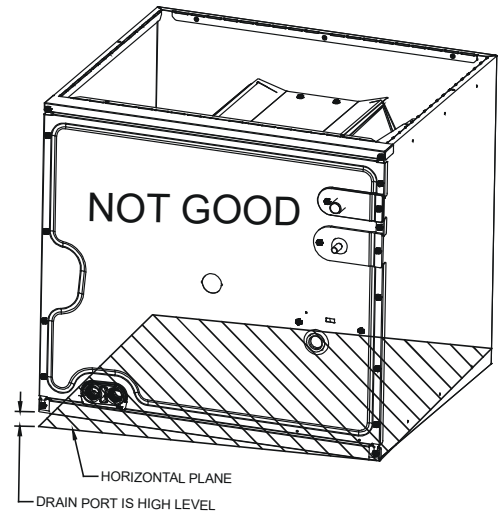
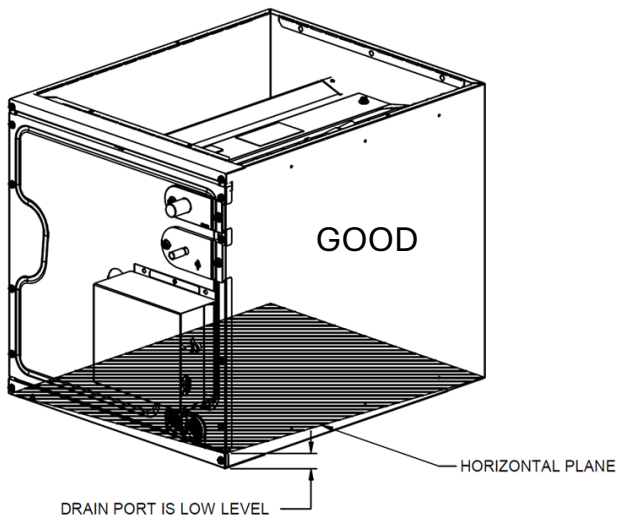

Figure 1

NOTE: The coil must be installed with the line set and drain openings to the front of the furnace or modular blower.

6.1 Filler Plates

Filler plates are supplied on all 17.5, 21.0 & 24.5 inch chassis to be used or adapting the unit to a furnace one size smaller. If the plenum and furnace openings are the same size, the filler plates must be removed. See Figure 2.

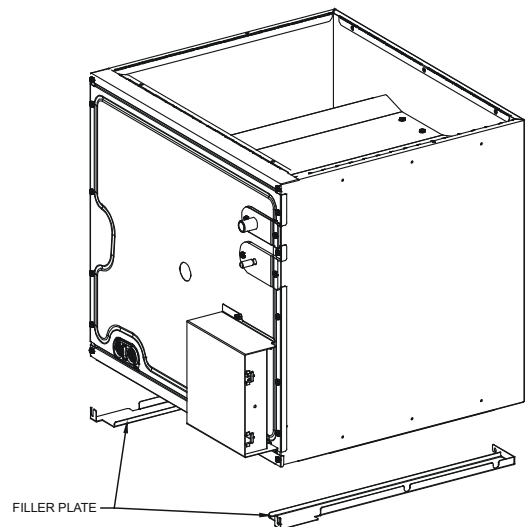
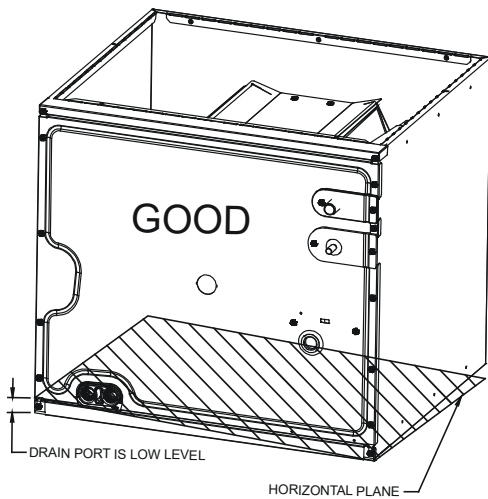
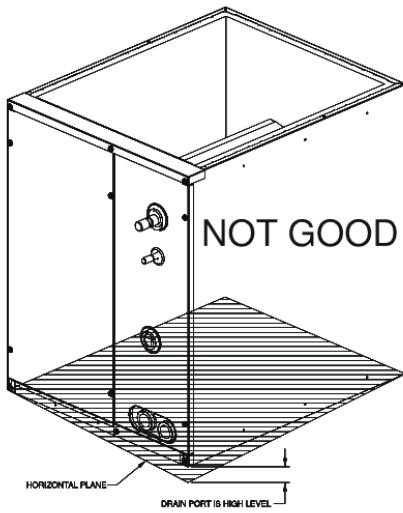

Figure 2

6.2 Insulation Kit

IMPORTANT NOTE: To prevent coil pan "sweating", a coil insulation kit (DPICX) must be applied to minimize pan sweating in applications where operating conditions exceed 80% RH. Insulation kits are available through your local distributor. The DPICX is not supplied with the cased coil.

See Table 3 for the correct DPICX and follow the instructions provided with the kit for installation.

Cased Coil	CAPEA2418B	CAPEA2418C	CAPEA4830D CAPEA6030D
	CAPEA3022B	CAPEA3022C	
	CAPEA3626B	CAPEA3626C	
		CAPEA4830C CAPEA6030C	
Kit Model	DPICX-BB	DPICX-CB	DPICX-DB

INSULATION KIT
Table 3

6.3 Down Flow Kit (For CAPEA4830C, D & CAPEA6030C, D)

IMPORTANT NOTE: To prevent coil “water leak”, a coil down flow kit (DFKE) must be installed when the coil is installed with down flow orientation regardless of the humidity. Down flow kits are available through your local distributor. The DFKE is not supplied with the cased coil.

See Table 4 for the correct DFKE and follow the instructions provided with the kit for installation.

Cased Coil	CAPEA2418B, CAPEA3022B, C CAPEA3626B, C, and D	CAPEA4830C, D CAPEA6030C, D
Kit Model	Not Necessary	DFKE-02

DOWN FLOW KIT
Table 4

7 RETURN DUCTWORK

Do not locate the return ductwork in an area that can introduce toxic or objectionable fumes/odors into the ductwork.

UV Lamp is only available for CAPEA: Clean Comfort brand UV coil purifiers also can be purchased from distributor. Maximum UV lamp diameter to be used per delta plate knockout design is 1.375” to reduce the possibility of air leak. Installer should apply the UV-C warning label on the maintenance panel when UV-C lamp is installed.

The power source must be installed external of the unit. Ensure that the wiring is routed through the Access Panel knockout with the grommet included. A magnetic door switch must be installed to avoid any accidental ultraviolet exposure during service. The power supply must be installed in parallel with the approve A2L control board utilizing the 24V AUX port to ensure that power to the UV is turned off during mitigation mode.

- Ultraviolet radiation hazard symbol IEC 60417-6040.
- Operator’s manual symbol ISO 7000-0790.

Refer to UV coil purifiers product specification and installation manual for additional details.

UV-C Part Numbers	
Models	Lamp
UC18S15-24	UCP-16013
UC18S15-24B	UCP-16012

 WARNING
<ul style="list-style-type: none"> - UNINTENDED USE OF APPLIANCES OR DAMAGE TO THE HOUSING MAY RESULT IN THE ESCAPE OF DANGEROUS UV-C RADIATION. - APPLIANCES THAT ARE OBVIOUSLY DAMAGED MUST NOT BE OPERATED. - UV-C BARRIERS BEARING THE ULTRAVIOLET RADIATION HAZARD SYMBOLS SHOULD NOT BE REMOVED. - DO NOT OPERATE UV-C LAMPS OUTSIDE OF THE APPLIANCE.

8 REFRIGERANT PIPING WORK

 WARNING
<p>ONLY BRAZING TECHNIQUES OR APPROVED MECHANICAL JOINTS SHOULD BE USED TO CONNECT REFRIGERANT TUBING CONNECTIONS. NON-APPROVED MECHANICAL CONNECTORS AND OTHER METHODS ARE NOT PERMITTED IN THIS SYSTEM CONTAINING R-32 REFRIGERANT. APPROVED MECHANICAL JOINTS WILL BE DETAILED IN THE PRODUCT’S SPECIFICATION SHEETS.</p>

NOTE: Refrigerant tubing must be routed to allow adequate access for servicing and maintenance of the unit.

Do not handle coil assembly with manifold or flowrator tubes. Doing so may result in damage to the tubing joints. Always use clean gloves for handling coil assemblies.

Installation of pipe-work must be kept to a minimum. Pipe-work including piping material, pipe routing and installation must be protected from physical damage and shall not be installed in an unventilated space. Equipment piping in an occupied space shall be installed in such a way to protect against accidental damage in operation and service. Precautions must be taken to avoid excess vibration or pulsation to refrigeration piping. Protection devices, piping and fittings shall be protected as far as possible against adverse environmental effects, for example, the danger of water collecting and freezing in relief pipes or the accumulation of dirt and debris. Steel pipes and components shall be protected against corrosion with a rustproof coating before applying any insulation, Any solenoid valves and piping in the refrigerant systems must be so designed and installed to minimize the likelihood of hydraulic shock damaging the system. Solenoid valves must be must not block in liquid refrigerant unless adequate relief is provided to the refrigerant system’s low pressure side. Provisions must be made for expansion and contraction of long runs of piping.

Follow standards related to ASHRAE 15, ASHRAE 15.2, IAPMO Uniform Mechanical Code, ICC International Mechanical Code or CSA B52 during any installation. Piping must be accessible for inspection prior to being covered or enclosed in compliance with national and local codes.

Flexible pipe elements must be protected against mechanical damage, excessive stress by torsion, or other forces. They should be checked for mechanical damage annually. The indoor equipment and pipes must be securely mounted and guarded such that accidental rupture of equipment cannot occur from such events as moving furniture or reconstruction activities. Field brazed joints indoors shall be tightness tested.

LEAK DETECTION AND EVACUATION METHODS

Extreme care shall be taken not to overfill the refrigerating system. Prior to recharging the system, it shall be pressure tested with the appropriate purging gas. **No refrigerant shall be used for pressure testing to detect leaks.** The system shall be leak tested on completion of charging prior to commissioning. A follow-up leak test shall be conducted prior to leaving the site.

Using dry nitrogen or dry helium, pressurize the system as mentioned below.

System Pressure Testing

Once all of the refrigerant line connections are completed, Perform a 3-step nitrogen pressure test as mentioned below. No refrigerant shall be used for pressure testing. Extreme care shall be taken not to over pressurize the system described in step 3.

1. Pressurize the system with nitrogen to 150 PSIG and hold for 3 minutes. If any pressure drops occur, locate, and repair leaks and repeat step 1.
2. Pressurize the system with nitrogen to 325 PSIG and hold for 5 minutes. If any pressure drops occur, locate, and repair leaks and repeat step 1.
3. Pressurize the system with nitrogen to Maximum Allowable Pressure as listed in the serial plate and hold for 1 hour (4 hours recommended). If any pressure drops occur, locate, and repair leaks and repeat step 1.

If leaks are found, repair them. After repair, repeat the leak pressure test described above.

If no leaks exist, proceed to system evacuation and charging.

The minimum test pressure for the low side of the system shall be the low side Maximum Allowable Pressure and the minimum test pressure for the high side of the system shall be the high side Maximum Allowable Pressure, unless the high side of the system cannot be isolated from the low side of the system in which case the entire system shall be pressure tested to the low side Maximum Allowable Pressure.

For system evacuation follow the below procedure:

1. Connect the vacuum pump with 250 micron capability to the service valves.
2. Evacuate the system to 500 microns or less using suction and liquid service valves. Using both valves is necessary.
3. Close pump valve and hold vacuum for 10 minutes. Typically pressure will rise during this period.
 - If the pressure rises to 500 microns or less and remains steady the system is considered leak-free; proceed to start-up.
 - If pressure rises above 500 microns moisture and /or noncondensables may be present or the system may have a small leak. Return to step 2: If the same result is encountered check for leaks as previously indicated and repair as necessary then repeat evacuation.



CAUTION

FOLLOW THE POINTS BELOW:

- USE A TUBE CUTTER AND FLARING BLOCK SUITABLE FOR THE TYPE OF REFRIGERANT.
- TO PREVENT DUST, MOISTURE OR OTHER FOREIGN MATTER FROM INFILTRATING THE PIPING, EITHER PINCH THE END OR COVER IT WITH TAPE.
- DO NOT ALLOW ANYTHING OTHER THAN THE DESIGNATED REFRIGERANT TO GET MIXED INTO THE REFRIGERANT CIRCUIT. IF AN REFRIGERANT GAS LEAKS WHILE WORKING ON THE UNIT, IMMEDIATELY VENTILATE THE ROOM.

Field brazed joints indoors shall be tightness tested. The test method shall have a sensitivity of 5 grams per year of refrigerant or better under a pressure of at least 0.25 times the maximum allowable pressure. No leak shall be detected (Should be leak tight).

8.1 Tubing Size/Length

Give special consideration to minimize the length of refrigerant tubing when installing cased coil. Refer to outdoor unit INSTALLATION & SERVICE REFERENCE for line set configuration guideline. If possible, allow adequate length or tubing such that the coil may be removed (for inspection or cleaning services) from the cabinet without disconnecting the tubing.

8.2 Cut Off The Spin Closure

- This coil is shipped containing gas under 150 P.S.I.G. Release pressure from the gas piping pressure-release device before initiating piping work.

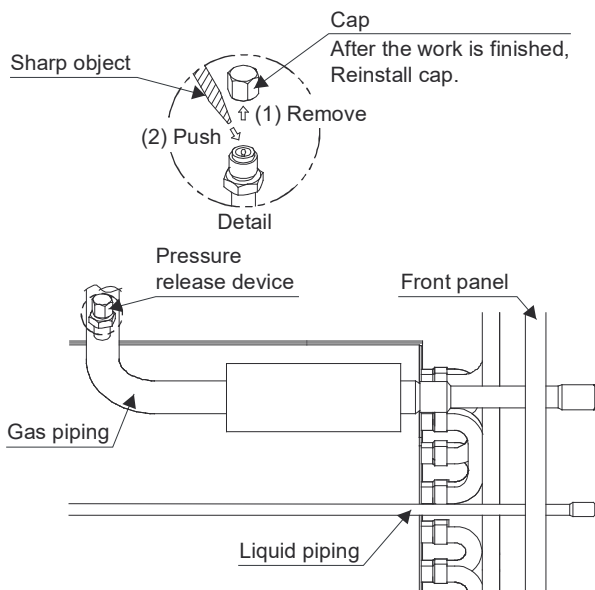

Figure 3

- Using a tube cutter, cut off the factory spun end of both the liquid and gas line piping.

8.3 Disconnect Internal Control Wiring

- Disconnect the control panel wiring from component wiring using the EEV, Pressure sensor and Thermistor connectors located on the outside of the control panel. See Figure 4.

NOTE: To prevent component wiring damage, the control panel should be removed from the front panel. Removing the control panel will assist in allowing the wiring to be safely pushed through the panel wireway. The control panel is detached from the front panel by removing the four mounting screws located on the four corners of the control panel.

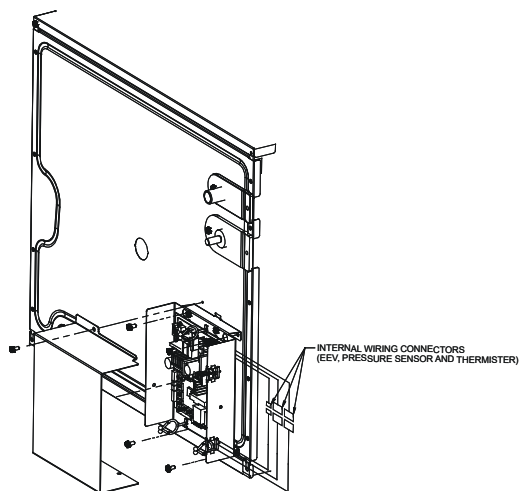

Figure 4

8.4 Connect Piping

This system must be charged with R32 Refrigerant in order to operate safely.

When breaking into the refrigerant circuit to make repairs - or for any other purpose - conventional procedures shall be used. However, for flammable refrigerants it is important that best practice be followed, since flammability is a consideration. The following procedures shall be adhered to:

- safely remove refrigerant following local and national regulations;
- evacuate;
- purge the circuit with inert gas (optional for A2L);
- evacuate (optional for A2L);
- continuously flush or purge with inert gas when using flame to open circuit; and
- open the circuit.

The refrigerant charge shall be recovered into the correct recovery cylinders if venting is not allowed by local and national codes.

For appliances containing flammable refrigerants, the system shall be purged with oxygen-free nitrogen to render the appliance safe for flammable refrigerants. This process might need to be repeated several times. Compressed air or oxygen shall not be used for purging refrigerant systems.

For appliance containing flammable refrigerants, refrigerant purging shall be achieved by breaking the vacuum in the system with oxygen-free nitrogen and containing to fill until the working pressure is achieved, then venting to atmosphere, and finally pulling down to a vacuum. This process shall be repeated until no refrigerant is within the system. When final oxygen-free nitrogen charge is used, the system shall be vented down to atmospheric pressure to enable work to take place.

Ensure that the outlet for the vacuum pump is not close to any potential ignition sources and that ventilation is available. Ensure that when brazing, any labels or wiring is sufficiently protected from damage.

For Single Front Panel

- Remove the front panel while cautiously guiding component wiring back through panel wireway.
- Unscrew two grommets both for gas and liquid tubing.
- Slide those grommets along field tubing.
- Braze up to the field piping fitting port while cooling the sensor, EEV, service valve and the thermal insulation. Braze joints should be made only with the connectors provided external to the cabinet. Do not alter the cabinet nor braze inside the cabinet. To avoid overheating after brazing, quench all brazed joints with water or a wet rag.

NOTE: To prevent damage caused by heat when brazing the field piping, cover the pipe insulation, the internal wiring, and the thermal sensors inside the insulation with a damp cloth. Otherwise, the sensors, EEV and service valve may be damaged by heat of brazing, which leads to a failure of normal operation.

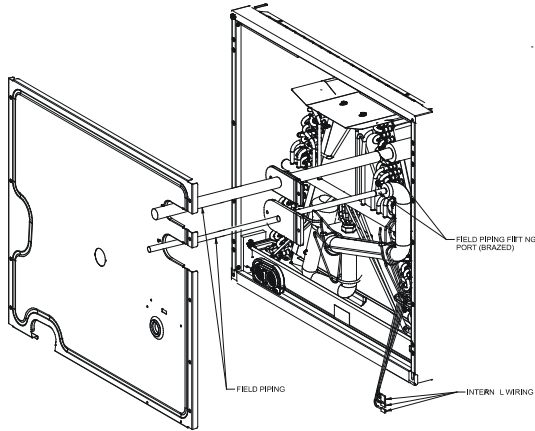

Figure 5

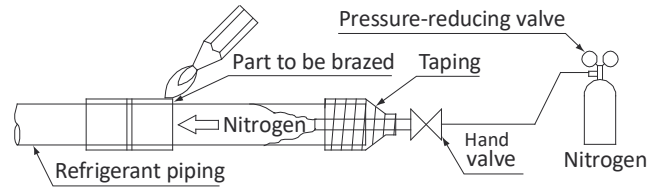

Figure 6

NOTE: Do not use flux when brazing refrigerant piping. Therefore, use the phosphor copper brazing filler metal (BCuP) which does not require flux. Flux has an extremely negative effect on refrigerant piping systems. For instance, if chlorine based flux is used, it will cause piping corrosion. Flux containing fluorine will damage refrigerant oil.

8.5 Re-assemble the Coil and Controls

- Once heat from the brazed area has dissipated, route component wiring back through the front panel wireway.
- Reinstall the tubing grommets and close the front panels.
- Reinstall the control panel to the front panel using mounting location holes and factory supplied screws.
- Reconnect Control Panel wiring to component wiring.
- After the work is finished, make sure to check that there is no gas leak.
- After checking for gas leaks, be sure to insulate the piping connections as shown in Figure 7.

In addition to conventional charge procedures, the following requirements shall be followed:

1. Ensure that contamination of different refrigerants does not occur when using charging equipment. Hoses or lines shall be as short as possible to minimize the amount of refrigerant contained in them.
2. R-32 Refrigerant Cylinders shall be kept in an appropriate position according to the instructions.
3. Ensure that the refrigeration system is earth grounded prior to charging the system with refrigerant.
4. Label the system when charging is complete (if not already).
5. Extreme care shall be taken not to overfill the refrigerating system.

Prior to recharging the system, it shall be pressure-tested with the appropriate purging gas. The system shall be leak-tested on completion of charging but prior to commissioning. A follow up leak test shall be carried out prior to leaving the site.

Completely insulate gas refrigerant piping in order to prevent condensation and possible water damage. Failing to insulate the pipes may cause leaking or burns. Be sure to use the insulation which can withstand temperatures of 250°F (120°C) or more. Reinforce the insulation on the refrigerant piping according to the installation environment. If environmental conditions may reach 86°F and 80% RH, condensate may form on the surface of the insulation. To prevent condensate leakage, reinforce the refrigerant piping insulation according to the installation environment.

WARNING
<p>A QUENCHING CLOTH IS STRONGLY RECOMMENDED TO PREVENT SCORCHING OR MARRING OF THE EQUIPMENT FINISH WHEN BRAZING CLOSE TO THE PAINTED SERVICES. USE BRAZING ALLOY OF 5% MINIMUM SILVER CONTENT.</p>

WARNING
<p>REFRIGERANT GAS MAY PRODUCE TOXIC GAS IF IT COMES IN CONTACT WITH FIRE (AS FROM A HEATER, STOVE OR COOKING DEVICE). EXPOSURE TO THIS GAS COULD CAUSE SEVERE INJURY OR DEATH.</p>

CAUTION
<p>APPLYING TOO MUCH HEAT TO ANY TUBE CAN MELT THE TUBE. TORCH HEAT REQUIRED TO BRAZE TUBES OF VARIOUS SIZES MUST BE PROPORTIONAL TO THE SIZE OF THE TUBE. SERVICE PERSONNEL MUST USE THE APPROPRIATE HEAT LEVEL FOR THE SIZE OF THE TUBE BEING BRAZED.</p>

CAUTION
<p>WHEN BRAZING THE REFRIGERANT PIPING, PERFORM NITROGEN REPLACEMENT FIRST OR PERFORM THE BRAZING WHILE FEEDING NITROGEN INTO THE REFRIGERANT PIPING. SEE FOLLOWING FIGURE. WHEN BRAZING PIPES WHILE FEEDING NITROGEN INSIDE THE PIPING, MAKE SURE TO SET THE NITROGEN PRESSURE TO 2.9 PSI OR LESS USING A PRESSURE REDUCING VALVE.</p>

WARNING
<p>USE OF OXYGEN COULD RESULT IN AN EXPLOSION RESULTING IN SERIOUS INJURY OR DEATH. USE ONLY DRY NITROGEN GAS.</p>

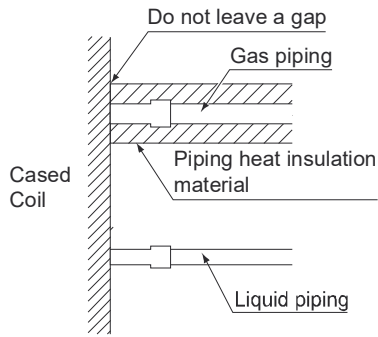

Figure 7



CAUTION

- DO NOT ALLOW COMPONENT WIRING TO BECOME PINCHED. FAILURE TO DO SO MAY LEAD TO UNIT FAILURE.
- BE SURE TO INSULATE GAS PIPING ALL THE WAY (REQUIRED INSULATION), TO PIPING CONNECTION INSIDE THE UNIT. ANY EXPOSED PIPING MAY CAUSE CONDENSATION OR BURNS IF TOUCHED.

9 SEALING ALONG THE PANEL GAP

IMPORTANT NOTE: To prevent cabinet “sweating”, apply field provided insulation tape along all joining surfaces between the coil, gas furnace, duct work, and panels. See Figure 8.

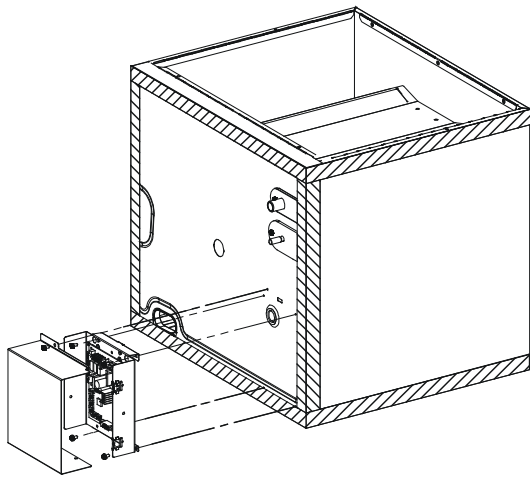

Figure 8

10 DRAIN PIPING WORK

In all cooling applications where condensate overflow may cause damage, a secondary drain pan must be provided by the installer and placed under the entire unit with a separate drain line properly sloped and terminated in an area visible to the owner. This secondary drain pan can provide extra protection to the area under the unit should be the primary drain plug up and overflow. As expressed in our product warranty, we will not be liable for any damages, structural or otherwise due to the failure to follow this installation requirement.

Condensate drain connections are located in the drain pan at the bottom of the coil/enclosure assembly see Figure 9. Use the female ($\frac{3}{4}$ "FPT) threaded fitting that protrudes outside of the enclosure for external connections. The connectors required are $\frac{3}{4}$ " NPT male, either PVC or metal pipe and must be hand tightened to a torque of no more than 37 in-lbs, to prevent damage to the drain pan connection. An insertion depth between .36 to .49 inches (3-5 turns) should be expected at this torque.

1. Ensure drain pan hole is NOT obstructed.
2. To prevent potential sweating and dripping on to finished space, it may be necessary to insulate the condensate drain line located inside the building. Use Armaflex® or similar material.

A secondary condensate drain connection has been provided for areas where the building codes require it. Use a downward slope of at least $\frac{1}{4}$ " per foot to provide free drainage, or as required by local code. Provide required support to the drain line to prevent bowing. If the secondary drain line is required, run the line separately from the primary drain and end it where condensate discharge can be easily seen.

Drain port labeled (A) in Figure 9 is the primary drain and condensate drain line must be attached to this drain port.

Drain port (B) is for the secondary drain line (if used).

Use Figure 11 as a template for typical drain pipe routing. This figure shows how to avoid interference with vent piping.

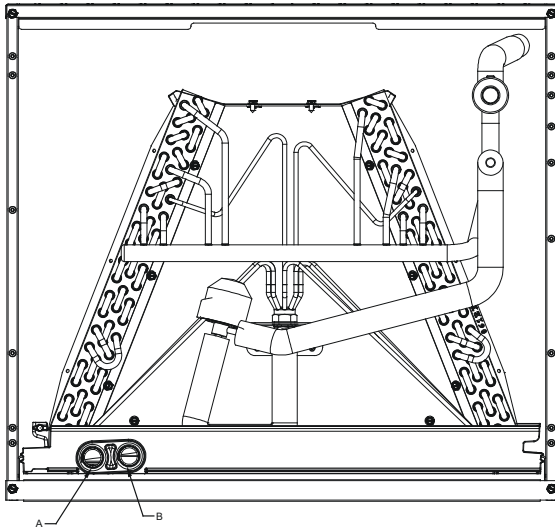
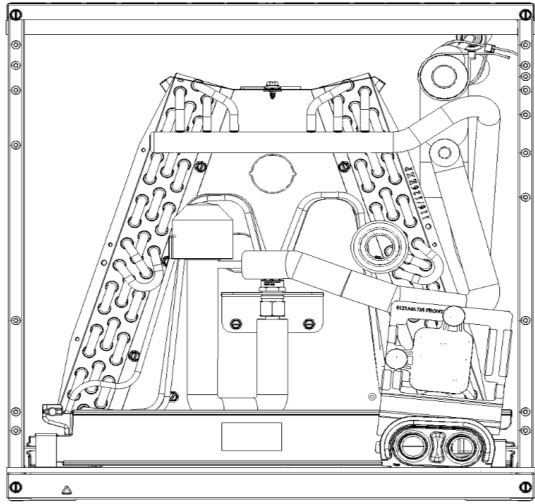

Figure 9

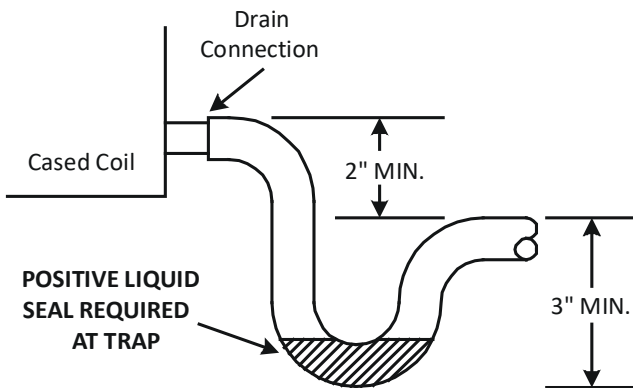

Figure 10

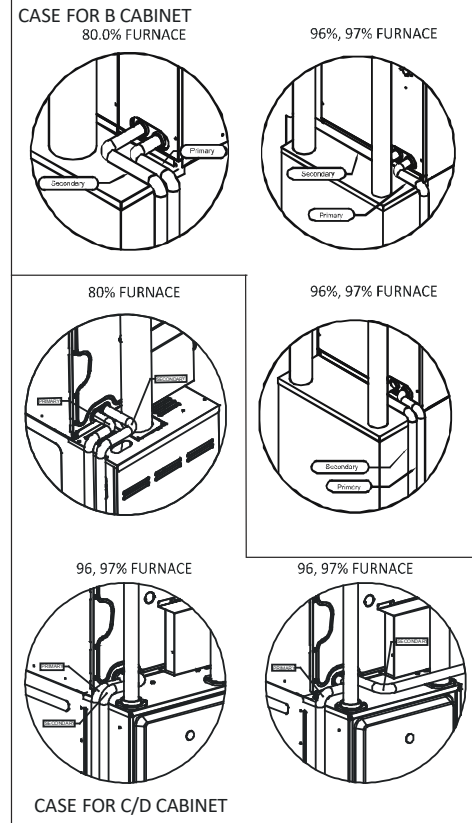

Figure 11



CAUTION

• USE STEEL DRAIN PIPE/FITTINGS, OR ADD REFLECTIVE OR HIGH HEAT RESISTIVE TAPE, TO ANY PIPE OR FIXTURES THAT IS WITHIN 1" OF THE 80% FURNACE VENT PIPE. FOIL-MASTIC SEALANT TAPE IS THE PREFERRED METHOD OF PIPE WRAPPING MATERIAL.



CAUTION

IF A SECONDARY DRAIN IS NOT INSTALLED, THE SECONDARY ACCESS MUST BE PLUGGED.

NOTE:

- Water coming from secondary line means the coil primary drain is plugged and needs immediate attention.
- Insulate drain lines located inside the building or above a finished living space to prevent sweating. The installation must include a "P" style trap that is located as close as is practical to the evaporator coil. See Figure 10 for details of a typical condensate line "P" trap.

NOTE: Units operating in high static pressure applications may require a deeper field constructed "P" style trap than is shown in Figure 10 to allow proper drainage and prevent condensate overflow.

- Trapped lines are required by many local codes. In the absence of any prevailing local codes, please refer to the requirements listed in the uniform mechanical building code.

- A drain trap in a draw-through application prevents air from being drawn back through the drain line during fan operation, thus preventing condensate from draining and if connected to a sewer line, to prevent sewer gases from being drawn into the air stream during blower operation.
- If using copper drain line, solder a short piece of pipe, minimum 6" length, to the connector before installing a drain fitting. DO NOT over torque the 3/4" copper connector to the plastic drain connection. Using a wet rag or heatsink material on the short piece to protect the plastic drain pan.

 CAUTION
<p>IF A SECONDARY DRAIN IS NOT INSTALLED, THE SECONDARY ACCESS MUST BE PLUGGED.</p>

Condensate drain traps with an open vertical Tee between the cased coil and the condensate drain trap can improve condensate drainage in some applications, but may cause excessive air discharge out of the open Tee. We do not prohibit this type of drain but we also do not recommend it due to the resulting air leakage. Regardless of the condensate drain design used, it is the installer's responsibility to ensure the condensate drain system is of sufficient design to ensure proper condensate removal from the coil drain pan.

Use of a condensate removal pump is permitted when necessary. This condensate pump should have provisions for shutting off the control voltage should a blocked drain occur. See Auxiliary Alarm Switch section that is in gas furnace or modular blower manual for more details. A trap must be installed between the unit and the condensate pump.

NOTE: This cased coil DOES NOT have auxiliary alarm switch feature.

IMPORTANT NOTE: The coil is fabricated with oils that may dissolve Styrofoam® and certain types of plastics. Therefore, the removal pump or float switch must not contain any of these materials.



Installation of pipe-work must be kept to a minimum. Pipe work including piping material, pipe routing and installation must be protected from physical damage and shall not be installed in an unventilated space. Equipment piping in any occupied space shall be installed in such a way to protect against accidental damage in operation and service. Precautions must be taken to avoid excessive vibration or pulsation to refrigeration piping. Protection devices, piping and fittings shall be protected as far as possible against adverse environmental effects, for example, the danger of water collecting and freezing in relief pipes or the accumulation of dirt and debris. Steel pipes and components shall be protected against corrosion with a rustproof coating before applying any insulation. Any solenoid valves and piping in the refrigerant systems must be so designed and installed to minimize the likelihood of hydraulic shock damaging the system. Solenoid valves must not block in liquid refrigerant unless adequate relief

is provided to the refrigerant system's low pressure side. Provisions must be made for expansion and contraction of long runs of piping.

11 ELECTRICAL WIRING WORK

IMPORTANT: All routing of electrical wiring must be made through provided electrical bushings. When routing electrical wiring through bushings, take care not to damage the PCB. Do not cut, puncture or alter the cabinet or control panel for electrical wiring.

 WARNING
<p>ALL ACCESSORIES THAT MAY BECOME A POTENTIAL IGNITION SOURCE IF INSTALLED. SUCH AS ELECTRONIC AIR CLEANERS, MUST ONLY BE POWERED THROUGH OUR ACCESSORY CONTROL BOARD KIT. IF AN ELECTRONIC AIR CLEANER IS ALREADY INSTALLED IN THE DUCT WORK AND NOT CONNECTED TO THE ACCESSORY CONTROL BOARD. IT WILL HAVE TO BE DISABLED OR REMOVED. ENSURE THAT ANY ADDITIONAL WIRING FROM THE INDOOR UNIT TO THE ACCESSORY CONTROL BOARD IS ROUTED AND PROTECTED FROM DAMAGE WEAR, AVOIDING THE FLUE PIPE AND ANY JOINTS THAT MAY NEED BRAZED OR DISCONNECTED FOR SERVICE. REFER TO THE PRODUCT SPECIFICATION SHEET FOR THE ACCESSORY CONTROL BOARD KIT PART NUMBER.</p>

 WARNING	
<p>HIGH VOLTAGE DISCONNECT ALL POWER BEFORE SERVICING OR INSTALLING THIS UNIT. MULTIPLE POWER SOURCES MAY BE PRESENT. FAILURE TO DO SO MAY CAUSE PROPERTY DAMAGE, PERSONAL INJURY OR DEATH.</p>	
<p>TO AVOID PROPERTY DAMAGE, PERSONAL INJURY OR DEATH DUE TO ELECTRICAL SHOCK, THIS UNIT MUST HAVE AN UNINTERRUPTED, UNBROKEN ELECTRICAL GROUND. THE ELECTRICAL GROUND CIRCUIT MAY CONSIST OF AN APPROPRIATELY SIZED ELECTRICAL WIRE CONNECT THE GROUND LUG IN THE UNIT CONTROL BOX TO THE BUILDING ELECTRICAL SERVICE PANEL. OTHER METHODS OF GROUND ARE PERMITTED IF PERFORMED IN ACCORDANCE WITH THE NATIONAL ELECTRIC CODE (NEC)/AMERICAN NATIONAL STANDARDS INSTITUTE (ANSI)/ NATIONAL FIRE PROTECTION ASSOCIATION (NFPA) 70 AND LOCAL/STATE CODES. IN CANADA, ELECTRICAL GROUNDING IS TO BE IN ACCORDANCE WITH THE CANADIAN ELECTRIC CODE (CSA C22.1).</p>	

11.1 General Instructions

- Shut off the power before doing any work.
- All field supplied parts and materials, electric works must conform to local codes.
- See also the "Wiring Diagram Label" located on the underside of the control panel cover.
- All wiring must be performed by a licensed electrician.
- The power wiring must be protected with safety devices in accordance with local and national codes i.e. a fuse, a circuit breaker or a GFCI. Further detail, see gas furnace or modular blower installation manual.
- To avoid short circuiting the power supply wire, be sure to use insulated terminals.
- Do not turn on the power supply (circuit breaker or a GFCI) until all other work is done.



WARNING

DO NOT GROUND UNITS TO WATER PIPING, TELEPHONE WIRES OR LIGHTNING RODS BECAUSE INCOMPLETE GROUNDING COULD CAUSE A SEVERE SHOCK HAZARD RESULTING IN SEVERE INJURY OR DEATH. DO NOT GROUND TO GAS PIPING. A GAS LEAK COULD RESULT IN CAUSING AN EXPLOSION WHICH COULD LEAD TO SEVERE INJURY OR DEATH.

11.2 Wiring Sizing

Use relay wire harness (including ground wire) as supplied with this unit for connection between cased coil and gas furnace or modular blower. If it must be replaced with wiring, use thicker wire gauge than AWG18 wire size for your unit. Wiring material must comply with local codes.



WARNING

FIRE HAZARD! TO AVOID THE RISK OF PROPERTY DAMAGE, PERSONAL INJURY OR FIRE, USE ONLY COPPER CONDUCTORS.

11.3 Safety Device

Every installation must include an NEC (USA) or CEC (Canada) approved overcurrent protection device. Also, check with local or state codes for any special regional requirements. Protection can be in the form of fusing or HACR style circuit breakers. The Series and Rating Plate provides the maximum overcurrent device permissible. When using residual current operated circuit breakers, be sure to use a high-speed type (0.1 second or less) 30m A rated residual operating current.

NOTE: Fuses or circuit breakers are to be sized larger than the equipment MCA but not to exceed the MOP.

11.4 Transformer Installation

Measure the power supply to the gas furnace or modular blower. Selection of correct supply voltage for transformer depends on measured power supply to gas furnace or modular blower. The supply voltage must be measured and be in agreement with the equipment's unit nameplate power requirements and within the range shown. 24 VAC power voltage is supplied to EEV cased coil control board from transformer supply terminals. See Figure 12. For appropriate wiring identification and installation for the cased coil, refer to the provided wiring schematic located on the PCB control panel cover.

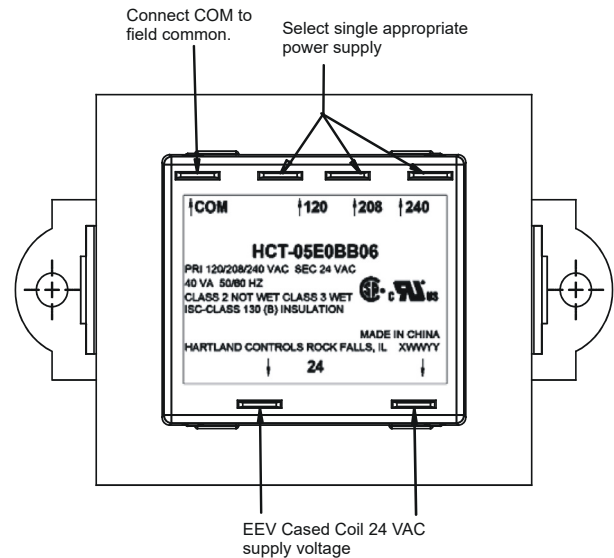

Figure 12

The cased coil PCB must be supplied 24 VAC supply voltage from an appropriately powered transformer. A transformer has been included with the cased coil.



WARNING

THIS UNIT IS DESIGNED TO OPERATE ON 24 VAC FROM PROVIDED TRANSFORMER. NEVER CONNECT HIGH VOLTAGE (120/208/240 VAC) TO THE CASED COIL DIRECTLY OR TO THE CASED COIL CONTROL BOARD. DOING SO WOULD RESULT IN EQUIPMENT DAMAGE AND/OR PERSONAL INJURY OR DEATH. USE DESIGNATED UL CERTIFIED TRANSFORMER INCLUDED WITH COIL. DO NOT ALTER OR MODIFY THE TRANSFORMER. ATTEMPTING TO MODIFY OR ALTER THE TRANSFORMER MAY RESULT IN PRODUCT DAMAGE OR PERSONAL INJURY.

11.5 How to Install the Transformer

Furnace application requires the use of the multi-tap (120/208/240) VAC to 24 VAC transformer. Appropriate supply voltage for the multi-tap transformer is based on field wiring. Select the following components from the coil transformer installation components:

1. Multi-tap (120/208/240) VAC to 24 VAC transformer.
2. Appropriate PCB transformer bracket (See Table 5).
3. Supplied red/black voltage transformer power wires.

NOTE: Based in furnace or blower selection, use Table 5 to determine appropriate PCB transformer bracket.

	Model Name	Cabinet Width	Bracket B	No Bracket
Gas Furnace	Upflow 80%	All	X	
	Upflow 96%	All	X	
	Upflow 97%	All	X	
	Upflow 80% + 96% ULN	All	X	
	Downflow 80%	All		X
	Downflow 96%	All	X	
	Downflow 97%	17.5"		X
	Downflow 97%	21.0"	X	
Modular Blower	Downflow 80% + 96% ULN	All		X
	MBVK*	All		X

Table 5

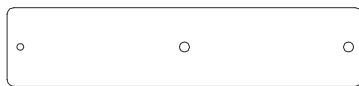

Bracket 'B'

Figure 13

NOTE: Based on furnace or modular blower model, the applicable bracket and PCB transformer are mounted inside the furnace or modular blower cabinet. It is recommended to use self tapping screws to secure the PCB transformer and bracket plate to the mounting position. See Figure 16 through 20 to determine appropriate location.

11.5.1A Installation Bracket -"B"

Furnace transformer should be removed from the PCB control deck. Align transformer bracket "B" and furnace transformer to the mounting holes of the furnace transformer on the PCB control deck. Bracket "B" should be located between the PCB control deck and furnace transformer. Secure innermost bracket mounting location and innermost furnace transformer mounting hole to the PCB control deck. Align multi-tap EEV cased coil transformer to transformer bracket "B" by overlapping the base of furnace transformer and securing transformers together to bracket and securing the left side of EEV transformer, using (1) self tapping, field supplied screw. See Figures 16-17.

For 80 / 96 / 97% / ULN Upflow Furnace

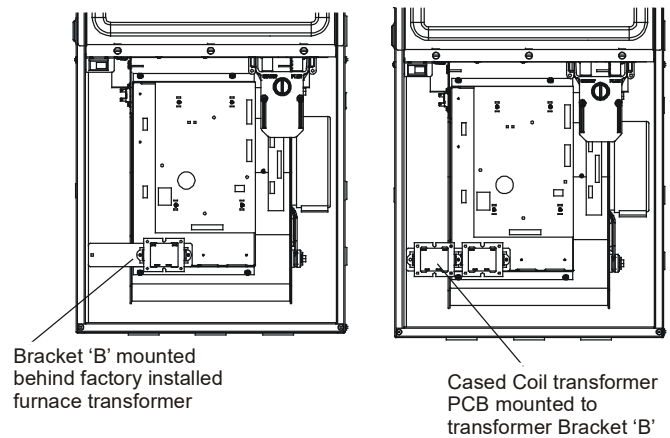

Figure 16

For 96% / 97% Downflow Furnace (21.0" Wide Cabinet)

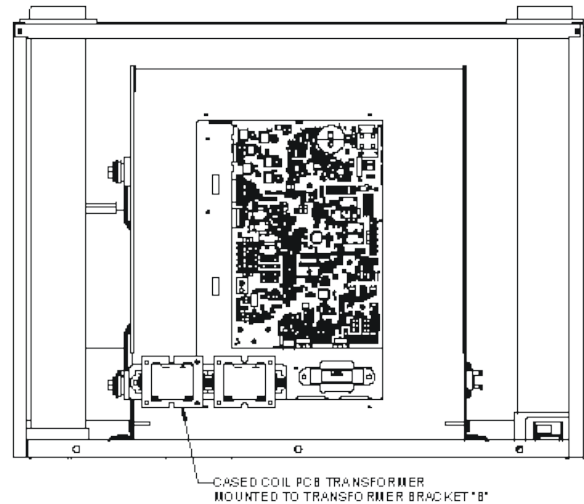

Figure 17

11.5.1B No Bracket Installation

For 80% Downflow Furnace and Downflow ULN

The PCB transformer can be assembled to the Furnace partition plate. Fasten the PCB transformer using (2) field supplied self drilling screws. Locate the transformer to the partition plate to the recommended location. See Figure 18. The transformer should be parallel to the edge of the heat shield. Self drilling screws should not be longer than 0.75" to prevent interference with blower housing.

NOTE: Extreme caution must be taken when installing the transformer to the partition plate and wiring the transformers so as to not damage the furnace control board, wiring or other electrical components.

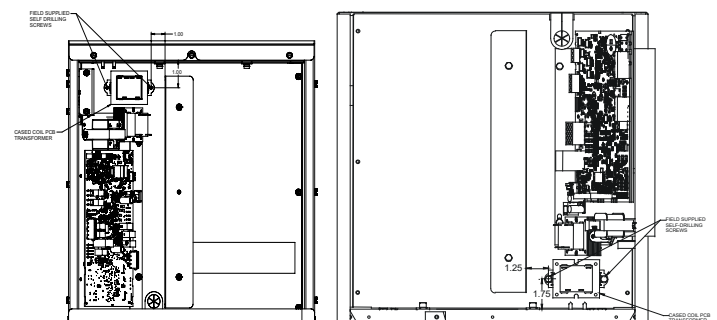

Figure 18

For 97% Downflow Furnace (17.5" Width Cabinet)

Fasten the PCB transformer using (1) field supplied screw at the extras screw hole on the PCB mounting plate. Then secure another screw hole of the PCB transformer using (1) field supplied, self drilling screw.

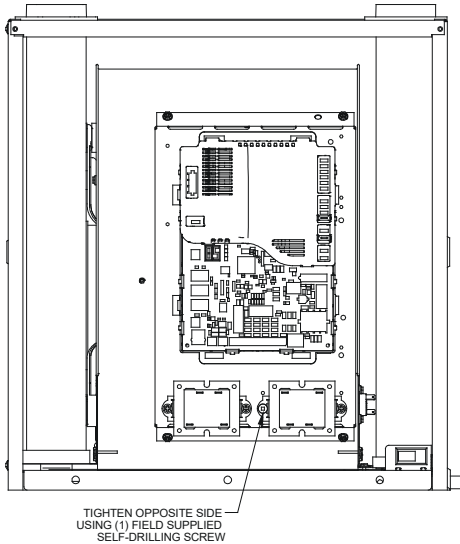
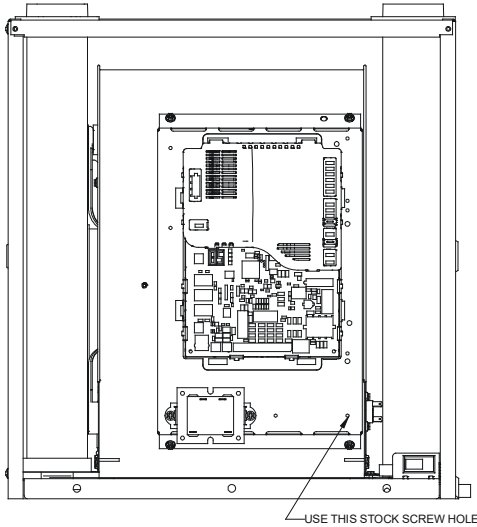

Figure 19

For the Modular Blower

Remove a screw located on the control deck that is showed in Figure 20 and affix the PCB transformer with the removed screw and a screw hole. Then secure another screw hole of PCB transformer using (1) field supplied self drilling screws.

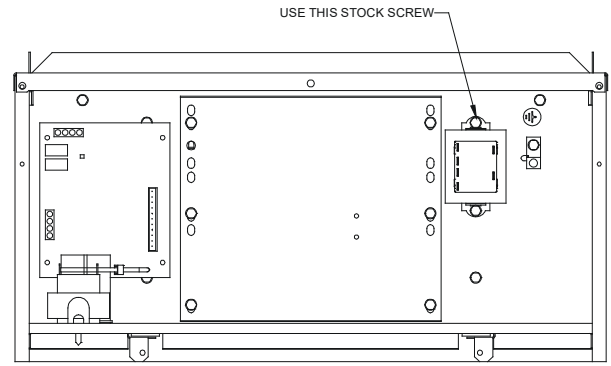

Figure 20

11.6 Wiring Transformer and PCB

IMPORTANT: When wiring PCB power supply to PCB transformer, an insulated bushing (field supplied) must be installed in the furnace or modular blower cabinet wall. Wiring must pass through bushing to interior of cabinet.

DO NOT ALLOW WIRING TO PASS ALONG AREAS WHERE WIRING IS EXPOSED TO ABRASIVE METAL EDGES. DO NOT ALTER BLOWER DECK.

To power PCB transformer: Use high voltage red and black wires provided in transformer installation components. Route red/black transformer power supply to PCB transformer from field wiring. Power and ground wiring for cased coil: Use accompanied yellow, purple and green wiring harness.

Communication wiring: Use accompanied black, grey, red and blue wire harness.

DO NOT POWER TO TR1/TH1 TERMINAL OF PCB WITH FACTORY INSTALLED FURNACE R/C THERMOSTAT POWER INSTEAD OF PCB TRANSFORMER.

NOTE: Create wire trap on outside of cabinet wall before passing into cabinet. The wire trap must remain below the insulated wire bushing location to prevent moisture intrusion into furnace or modular blower cabinet and onto electrical components.

	CAUTION
---	----------------

OUTSIDE THE CASED COIL, DO NOT ROUTE TRANSMISSION WIRING TOGETHER WITH OTHER ELECTRICAL WIRING. KEEP THE TRANSMISSION WIRING AT LEAST 2 IN. (50MM) AWAY FROM THE POWER WIRING AND OTHER ELECTRICAL WIRING. EFFECTS OF ELECTRICAL INTERFERENCE (EXTERNAL NOISE) MAY RESULT IN MALFUNCTION AND BREAKDOWN.

	WARNING
---	----------------

USE ONLY SPECIFIED WIRE AND CONNECT TO TERMINALS TIGHTLY. BE CAREFUL THAT WIRES DO NO PLACE EXTERNAL STRESS ON TERMINALS. KEEP WIRE IN NEAT ORDER; NOT TO OBSTRUCT OTHER EQUIPMENT. MAKE SURE THAT THE CONTROL PANEL COVER IS CLOSED TIGHTLY. INCOMPLETE CONNECTIONS COULD RESULT IN OVERHEATING, AND IN WORSE CASES, ELECTRICAL SHOCK OR FIRE.

11.7 Sensor and Accessory Wiring

Refer to Table 2 for minimum conditioned room area requirements.

R-32 sensor fault codes should be referenced through the corresponding R-32 equipped furnace or accessory IO manuals. It is the installer's responsibility to ensure that mitigation mode is operational. A test can be performed after installation to ensure that this is the case.

Sensor is not intended for service or repair. If the sensor is not functioning properly, mitigation mode will engage and the sensor must be replaced by removing the old sensor from the bracket and re-installing with new push-pins and a zip-tie. The R-32 sensor shall only be replaced with sensor specified by the appliance manufacturer. (Sensor replacement part can be determined through the homeowner support line provided earlier in the document.)

All wiring installed in the field to be used in conjunction with the sensor must meet the following minimum specification:

- 18 AWG
- 1.58mm insulation thickness or protected from damage

The R-32 sensor must be installed and powered for service. Ensure that the grommet is installed through the access panel knockout hole. Sensor bracket assemblies are shipped with two zip-ties, one of which is designed for strain relief. This zip-tie must be kept attached to bracket and wiring. Follow routing diagram as shown in Figure 25 or 26 depending on orientation of install. This wiring is intended to be passed through the access hole on the furnace. If a hole must be cut in to the furnace, ensure that the wiring is well protected from mechanical damage and that the hole is free from burrs or sharp edges. Utilize a protective coating for all exposed metallic edges.

Check for the wiring diagram as seen at the end of this manual. If the sensor used in this unit must be routed through the Non-A2L Furnace Integration Kit, then reference the Non-A2L Furnace Integration Kit installation manual for further instructions.

For any and all accessories which may become a potential ignition source, they must be installed to an AUX port on either the furnace or Non-A2L Furnace Integration Kit. Ensure that any additional wiring from the cased coil is done so as to protect from damage and wear, avoiding the flue pipe and any joints which may need to be brazed or disconnected for service. If a zone controller must be powered through a zone-control kit to ensure that the zoning dampers actuate during mitigation mode. Refer to the product specification sheet for the zoning and the accessory control kit part number.

Check that wiring will not be subject to wear, corrosion, excessive pressure, vibration, sharp edges or any other adverse environmental effects. The check shall also take into account the effects of aging or continual vibration from sources such as compressors or fans.

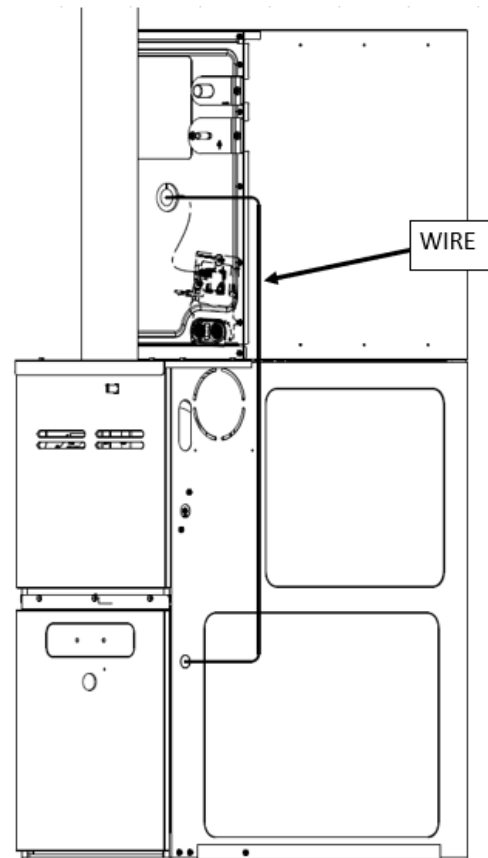

Figure 25 - Upflow Wire Routing

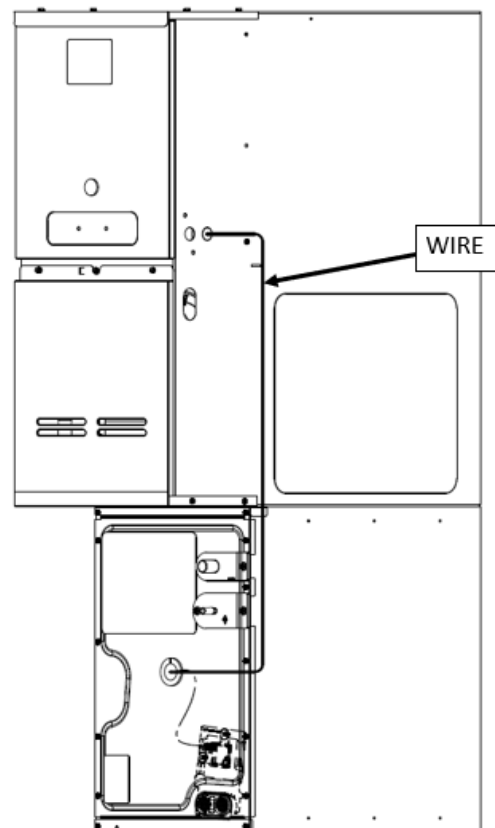

Figure 26 - Downflow Wire Routing



WARNING

WHEN INSTALLING THE WIRING, MAKE SURE THAT WIRING IS NEAT AND DOES NOT TOUCH SHARP EDGE OF SHEET METAL AND DOES NOT CAUSE THE CONTROL PANEL TO STICK UP, AND THEN CLOSE THE COVER FIRMLY. WHEN ATTACHING THE CONTROL COVER, MAKE SURE YOU DO NOT PINCH ANY WIRES.

12 FULLY COMMUNICATING SYSTEM

12.1 Overview

The Communicating system is a system that includes a Communicating compatible cased coil and outdoor unit with a communicating thermostat. System may ONLY be installed using an approved communicating thermostat.

A Communicating heating/air conditioning system differs from a non-communicating/traditional system in the manner in which the indoor unit, outdoor unit and thermostat interact with one another. In a traditional system, the thermostat sends commands to the indoor and outdoor units via analog 24 VAC signals. It is a one-way communication path. The indoor and outdoor units typically do not return information to the thermostat.

On the other hand, the indoor unit, and thermostat comprising a Communicating system “communicate” digitally with one another. It is now a two-way communications path. The thermostat still sends commands to the indoor and outdoor units and may also request and receive information from both the indoor and outdoor units. This information may be displayed on the Communicating thermostat. The indoor and outdoor units also interact with one another. The outdoor unit may send commands to or request information from the indoor unit. This two-way digital communications between the thermostat and subsystems (indoor/outdoor unit) is the key to unlocking the benefits and features of the Communicating system.

12.2 Wire Harness Instructions

For proper installation and to achieve a stable communication network, we strongly recommend to install the wire harness components that comes in the cased coil literature bag.

A) Wire Harness for Furnace Installation with Cased Coil

1. Make sure power is off to equipment
2. Remove Wire Harness from Literature bag.
3. Connect male Molex Plugs on the Wire Harness to female Molex Plugs coming from the control box on the cased coil.
4. Route field supplied data wires for the outdoor unit and the harness’s thermostat wiring through the furnace wire grommet.
5. Connect wires to the furnace phoenix connector before inserting onto the PCB slot, matching terminals 1, 2, R, C.
6. Run the harnesses low voltage wiring (yellow, purple, and green) through the furnace wire grommet to the additional transformer inside the furnace cabinet.
7. Run the harnesses low voltage wiring (blue, red, gray and black) through the cased coil wire grommet to the thermostat.

8. View Figure 21 for reference of Wire Harness Setup.

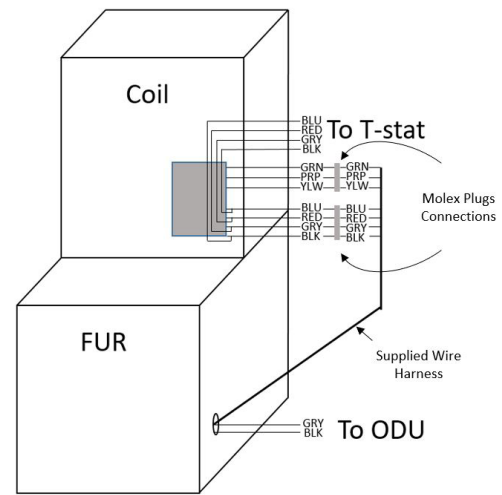

Figure 21

B) Wire Harness for Modular Blower Installation with Cased Coil

1. Make sure power is off to the equipment
2. Remove Wire Harness from Literature bag.
3. Connect male Molex Plugs on the Wire Harness to female Molex Plugs coming from the control box on the cased coil.
4. Route field supplied data wires for the outdoor unit and the harness’s thermostat wiring through the modular blower’s wire grommet.
5. Connect wires to the blower phoenix connector before inserting onto the PCB slot, matching terminals 1, 2, R, C.
6. Run the harnesses low voltage wiring (yellow, purple, and green) through the blower wire grommet to the additional transformer inside the blower cabinet.
7. Run the harnesses low voltage wiring (blue, red, gray and black) through the cased coil wire grommet to the thermostat.
8. View Figure 22 for reference of Wire Harness Setup.

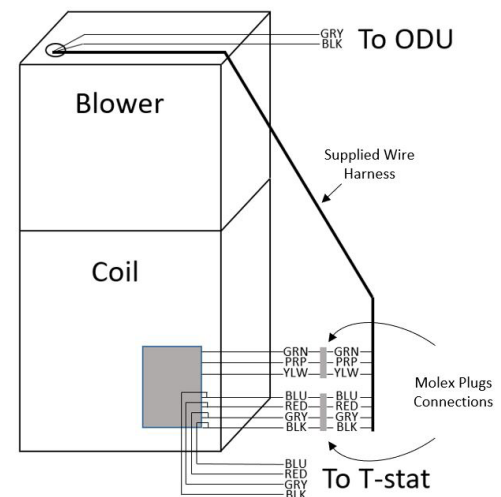

Figure 22

12.3 Thermostat Wiring

NOTE: Refer to section 11. ELECTRICAL WIRING WORK for 24 volt line connections to the cased coil.

NOTE: Only use approved communicating thermostats. Approved communicating thermostats are Daikin *ONE+* smart thermostat, and Amana® brand smart thermostat.

NOTE: A plug connector is provided with the control to make thermostat wire connections. Wire nuts are recommended to ensure one wire is used for each terminal. Failure to do so may result in intermittent operation.

Typical 18 AWG thermostat wire may be used to wire the system components. However, communications reliability may be improved by using a high quality, shielded, twisted pair cable for the data transmission lines.

12.4 Two-Wire Outdoor and Four-Wire Indoor Wiring

Typical wiring will consist of two wires between the indoor unit and outdoor unit and four wires between the indoor unit and thermostat. Figure 23 shows the required wires are: data lines, 1 and 2; “R” (24 VAC hot) and “C” (24 VAC common).

(1) A2L Compatible Gas Furnace

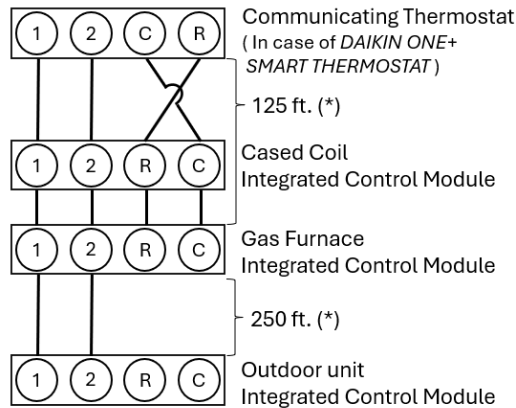

(*) Allowable Maximum Length

(2) Non-A2L Compatible Gas Furnace or Modular Blower (*1)

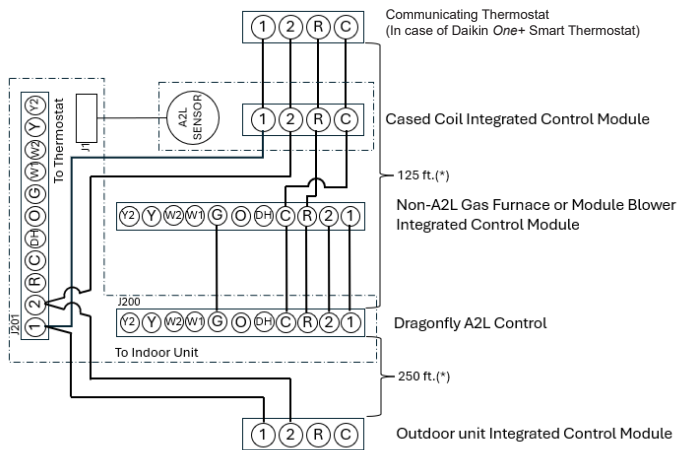

(*) Allowable Maximum Length

(*1) NOTE:
In case of using non-A2L Compatible gas furnace or modular blower, refer to "NON-A2L GAS FURNACE INTEGRATION KIT (DRAGONFLY KIT)" for details.

Figure 23 - System Wiring

12.5 Airflow Trim

Indoor airflow can be trimmed up/down through the outdoor unit user menu. For more detailed information, please refer to the outdoor unit installation manual.

NOTE: Trim Setting of the following combinations are restricted.

For R410-A		
Outdoor Unit	3 Ton	
Indoor Unit	G*VC800803B A*VC800803B D*80VC0803B	Trim settings higher than 10% are not allowed.
	G*VC960403B/603B A*VC960403B/603B D*96VC0403B/603B	
	G*VM970603B A*VM970603B D*97MC0603B	
For R-32		
Outdoor Unit	3 Ton	
Indoor Unit	G*VT800803B A*VT800803B D*80TC0803B	Trim settings higher than 10% are not allowed.
	G*VT960403B/603B A*VT960403B/603B D*96TC0403B/603B	
	G*VM970603B A*VM970603B D*97MC0603B	
Modular Blower	MBVK12BP1X0	Trim settings higher than 10% are not allowed.

13 MISCELLANEOUS START-UP CHECKLIST

- Prior to start-up, ensure that all electrical wires are properly sized and all connections are properly tightened.
- Tubing must be leak free.
- Condensate line must be trapped and pitched to allow for drainage.
- Auxiliary drain is installed when necessary and pitched to allow for drainage.
- Low voltage wiring is properly connected.
- Unit is protected from vehicular or other physical damage.
- Return air is not obtained from, nor are there any return air duct joints that are unsealed in areas where there may be objectionable odors, flammable vapors or products of combustion such as carbon monoxide (CO), which may cause serious personal injury or death.

MAXIMUM ALLOWED CFM		
Model Name	Upflow	Downflow
CAPEA2418B3*	910	910
CAPEA2418C3*	910	910
CAPEA3022B3*	1160	1160
CAPEA3022C3*	1160	1160
CAPEA3626B3*	1450	1260
CAPEA3626C3*	1450	1260
CAPEA3626D3*	1450	1450
CAPEA4830C3*	1520	1450
CAPEA4830D3*	1520	1450
CAPEA6030C3*	1890	1890
CAPEA6030D3*	1890	1890

14 TROUBLESHOOTING

14.1 Electrostatic Discharge (ESD) Precautions

NOTE: Discharge your body's static electricity before touching unit. An electrostatic discharge can adversely affect electrical components.

Use the following precautions during cased coil installation and servicing to protect the integrated control module from damage. By putting the cased coil, the control, and the person at the same electrostatic potential, these steps will help avoid exposing the integrated control module to electrostatic discharge. This procedure is applicable to both installed and uninstalled (ungrounded) cased coils.

1. Disconnect all power to the whole system. Do not touch the integrated control module or any wire connected to the control prior to discharging your body's electrostatic charge to ground.
2. Firmly touch a clean, unpainted, metal surface of the cased coil near the control. Any tools held in a person's hand during grounding will be discharged.
3. Service integrated control module or connecting wiring following the discharge process in step 2. Use caution not to recharge your body with static electricity; (i.e., do not move or shuffle your feet, do not touch ungrounded objects, etc.) If you come in contact with an ungrounded object, repeat step 2 before touching control or wires.
4. Discharge your body's electrostatic charge to ground before removing a new control from its container. Follow steps 1 through 3 if installing the control on a unit. Return any old or new controls to their containers before touching any ungrounded object.

14.2 Diagnostic Chart

Refer to the *Troubleshooting Chart* on the following page for assistance in determining the source of unit operational problems. The 7 segment LED display will provide any active fault codes.

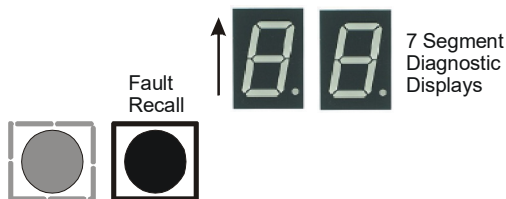

Figure 24

14.3 Fault Recall

The integrated control module is equipped with a momentary push-button switch that can be used to display the last six faults on the 7 segment LED display. Follow sequence below to use the feature. The control must be in Standby Mode (no thermostat inputs).

1. Press FAULT RECALL button for 2 to 5 seconds*, so that 7 segment displays show “- -”.
2. Release FAULT RECALL button in this period, 7 segment displays show the most recent fault.
3. Each time FAULT RECALL button is pressed after that**, 7 segment displays output next occurred fault.
4. After displaying the series of recent faults, 7 segment displays blink “- -” and goes back to Standby Mode.

To clear the error code history:

1. Press FAULT RECALL button for 10 to 15 seconds***, so that 7 segment blinks “- -”.
2. Release FAULT RECALL button in this period, 7 segment displays shows “88” and faults are cleared.

NOTE:

* If the FAULT RECALL button is not pressed long enough (2 to 5 seconds), control goes back to Standby Mode.

If the FAULT RECALL button is pressed for 5 to 10 seconds, the control goes back to Standby Mode.

** Consecutively repeated faults are displayed a maximum of three times.

*** If FAULT RECALL button is pressed for longer than 15 seconds, control goes back to Standby Mode.

14.4 Network Troubleshooting

The Communicating system is a full communicating system, constituting a network. Occasionally the need to troubleshoot the network may arise. The integrated cases coil control has some onboard tools they are, red communications LED, green receive (Rx) LED, and the learn button. Refer to the Communications Troubleshooting Chart on the following page for the error codes, possible causes and corrective actions.

- Red communications LED - indicates the status of the network. The Communications Troubleshooting Chart on the following page indicates the LED status and the corresponding potential problem.
- Green receive LED - indicates network traffic. The following table indicates the LED status and the corresponding potential problem.
- Learn button - used to reset the network. Depress the button for greater than 5 seconds to reset the network.

14.5 System Troubleshooting

NOTE: Refer to the instructions accompanying the Communicating compatible outdoor unit for unit specific troubleshooting information. Refer to the Troubleshooting Chart for the following page for a listing of possible cased coil error codes, and possible causes and corrective actions.

Under no circumstances shall potential sources of ignition be used in the searching for or detection of refrigerant leaks.

A halide torch (or any other detector using a naked flame) shall not be used. If a leak is suspected, all naked flames shall be removed/extinguished. If a leakage of refrigerant is found which requires brazing, all of the refrigerant shall be recovered from the system, or isolated (by means of shut off valves) in a part of the system remote from the leak.

The following leak detection methods have been deemed acceptable, provided proper care is taken in their implementation:

1. Electronic leak detectors rated for use with R32 refrigerant. Ensure the detection equipment is calibrated in a refrigerant-free area and that the leak detector itself is not a potential source of ignition. Leak detection equipment shall be set at a value of no more than 0.075 kg/m³.
2. Leak detection fluids - such as the bubble method or fluorescent method. Ensure that the use of detergents containing chlorine are avoided as they chlorine may react with the refrigerant and corrode the pipe-work.

Do not apply any permanent inductive or capacitance loads to the circuit without ensuring that this will not exceed the permissible voltage and current permitted for the equipment in use.

Check that cabling (wiring) will not be subjected to wear, corrosion, excessive pressure, vibration, sharp edges or any other adverse environmental effects. The check shall also take into account the effects of aging or continual vibration from sources such as compressors or fans.

COMMUNICATIONS TROUBLESHOOTING CHART

LED	LED Status	Indication	Possible Causes	Corrective Action(s)	Notes & Cautions
Red Communications LED	Off	<ul style="list-style-type: none"> None 	<ul style="list-style-type: none"> None 	<ul style="list-style-type: none"> None 	<ul style="list-style-type: none"> None
	1 Flash	<ul style="list-style-type: none"> Communications Failure 	<ul style="list-style-type: none"> Communications Failure 	<ul style="list-style-type: none"> Depress Learn Button Verify wiring connection 	<ul style="list-style-type: none"> Depress once quickly for a power-up reset Depress and hold for 5 seconds for an out-of-box reset
	2 Flashes	<ul style="list-style-type: none"> Out-of-box reset 	<ul style="list-style-type: none"> Control power up Learn button depressed 	<ul style="list-style-type: none"> None 	<ul style="list-style-type: none"> None
Green Receive LED	Off	<ul style="list-style-type: none"> No power Communications error 	<ul style="list-style-type: none"> No power to cased coil Open fuse Communications error 	<ul style="list-style-type: none"> Check fuses and circuit breakers; replace/reset Replace blown fuse Check for shorts in low voltage wiring in cased coil/system Reset network by depressing learn button Check data 1/data 2 voltages Typically the data 1 line is approximately 2.8 VDC and the data 2 transmission line is approximately 2.2 VDC. The voltage difference between data 1 and data 2 must be 0.6 VDC. 	<ul style="list-style-type: none"> Turn power OFF prior to repair
	1 Steady Flash	<ul style="list-style-type: none"> No network found 	<ul style="list-style-type: none"> Broken/ disconnected data wire(s) Cased coil is installed as a non-communicating/traditional system 	<ul style="list-style-type: none"> Check communications wiring (data 1/data 2 wires) Check wire connections at terminal block Verify cased coil installation type (non-communicating/traditional or communicating) Check data 1/data 2 voltages 	<ul style="list-style-type: none"> Turn power OFF prior to repair Verify wires at terminal blocks are securely twisted together prior to inserting into terminal block Verify data 1 and data 2 voltages as described above
	Rapid Flashing	<ul style="list-style-type: none"> Normal network traffic 	<ul style="list-style-type: none"> Control is "talking" on network as expected 	<ul style="list-style-type: none"> None 	<ul style="list-style-type: none"> None
	On Solid	<ul style="list-style-type: none"> Data 1/Data 2 miss-wire 	<ul style="list-style-type: none"> Data 1/data 2 wires reversed at cased coil, thermostat, or Communicating compatible outdoor unit Short between data 1/ data 2 wires Short between data 1 or data 2 wires and R (24VAC) or C (24VAC common) 	<ul style="list-style-type: none"> Check communications wiring (data 1/data 2 wires) Check wire connections at terminal block Check data 1/data 2 voltages 	<ul style="list-style-type: none"> Turn power OFF prior to repair Verify wires at terminal blocks are securely twisted together prior to inserting into terminal block Verify data 1 and data 2 voltages as described above

TROUBLESHOOTING

Error CODE	PCB LED DISPLAY	ClimateTalk MESSAGE	DESCRIPTION	POSSIBLE CAUSES	CORRECTIVE ACTIONS
EE	No display (EE display is EMG mode)	INTERNAL FAULT	<ul style="list-style-type: none"> No 24 volt power to PCB Blown fuse or circuit breaker PCB has an internal fault 	<ul style="list-style-type: none"> Manual disconnect switch OFF No 24 volt power to PCB Blown fuse or faulty circuit breaker Control board has internal fault 	<ul style="list-style-type: none"> Assure 24 volt power to blower and control board. Check fuse F2U on control board Check for possible short in 115/230 volt and 24 volt circuits. Repair as necessary. Replace the control board.
d0	E_d0	Data Not Yet On Network (NO NET DATA)	Data Not Yet On Network	<ul style="list-style-type: none"> No shared data on the network 	<ul style="list-style-type: none"> Populate shared data set using memory card.
d4	E_d4	Invalid Memory Card Data (INVALID MC DATA)	Invalid Memory Card Data	<ul style="list-style-type: none"> Wrong memory card data 	<ul style="list-style-type: none"> Replace circuit board Rewrite data using the correct memory card
70	E_70	EEV OPEN CKT	EEV disconnection detected	<ul style="list-style-type: none"> Indoor EEV coil not connected Incorrect wiring to EEV 	<ul style="list-style-type: none"> Check Indoor EEV coil connection (PCB and junction connector) Replace EEV coil Check the resistance value of EEV coil (refer service manual) Replace the control board
73	E_73	LIQ TEMP FLT	Liquid side thermistor abnormality	<ul style="list-style-type: none"> Open (or) short circuit of the liquid thermistor (X5A) Liquid thermistor reading incorrect or values outside the normal range 	<ul style="list-style-type: none"> Check the connection to liquid thermistor (PCB and junction connector) Check the resistance value of the thermistor (refer service manual) Replace thermistor Replace the control board
74	E_74	GAS TEMP FLT	Gas side thermistor abnormality	<ul style="list-style-type: none"> Open (or) short circuit of the gas thermistor (X5A) Gas thermistor reading incorrect or values outside the normal range 	<ul style="list-style-type: none"> Check the connection to gas thermistor (PCB and junction connector) Check the resistance value of the thermistor (refer service manual) Replace thermistor Replace the control board
75	E_75	PRESSURE FLT	Pressure sensor abnormality	<ul style="list-style-type: none"> Open (or) short circuit of the Pressure Sensor (X15A) Pressure Sensor reading incorrect or values outside the normal range 	<ul style="list-style-type: none"> Check the connection to pressure sensor (PCB and junction connector) Check the output voltage of the pressure sensor (refer service manual) Replace pressure sensor Replace the control board
76	E_76	EQUIP COMM LOSS	Outdoor unit - Gas furnace or Blower unit communication error (during operation)	<ul style="list-style-type: none"> Open communication circuit Incorrect wiring between OD unit, Gas furnace or Modular blower No power supply to OD unit, Gas furnace or Modular blower <Hereafter, when using "Non-A2L Furnace Integration Kit"> See "Communication Error" (When using "Non-A2L Furnace Integration Kit") below. 	<ul style="list-style-type: none"> Check for cased coil and other unit wiring. Replace the control board Check power supply to OD unit, Gas furnace or Modular blower Check if the blower of the gas furnace or blower unit is running and the LED display on the non-A2L Furnace Integration Kit indicates a refrigerant leak condition and if it is determined that there is a leak, immediately ventilate. Then, take measures to prevent leaks. <Hereafter, when using "Non-A2L Furnace Integration Kit"> See "Communication Error" (When using "Non-A2L Furnace Intergration Kit") below.
77	E_77	TSTAT ID NO COM	Indoor Unit Thermostat communication error (start-up & during operation)	<ul style="list-style-type: none"> Incorrect wiring between ID unit and thermostat. The system may have the communication error without error code 77 on the indoor PCB. Follow section 14.5 SYSTEM TROUBLESHOOTING Thermostat failure Power interruption (low voltage) 	<ul style="list-style-type: none"> Check for thermostat and indoor unit wiring Verify the input voltage at the ID unit and thermostat After recovering the system with power supply, TSTAT ID NO COM will continue to be displayed on the thermostat within 2 minutes. The error code will be cleared automatically. Replace control board or thermostat Press "LEARN" button on PCB for more than 5 seconds to reestablish network
78	E_78	CONNECT EQUIP	Outdoor unit - Gas furnace or Blower unit communication error (Startup operation)	<ul style="list-style-type: none"> Open communication circuit Incorrect wiring between OD unit, Gas furnace or Modular blower No power supply to OD unit, Gas furnace or Modular blower 	<ul style="list-style-type: none"> Check for cased coil and other unit wiring. Replace the control board Check power supply to OD unit, Gas furnace or Modular blower

Items below are messages only displayed on the thermostat screen.			
communication error	-	The thermostat cannot communicate with other units.	<ul style="list-style-type: none"> • Communication wiring disconnected. <p><Hereafter, when using "NON A2L FURNACE INTEGRATION KIT"></p> <ul style="list-style-type: none"> • A2L sensor disconnected • A2L sensor failure • A2L refrigerant leak detection <p>*1) in the case of the above factors, the blower will continue to operate.</p> <p>*2) Please confirm the certain status by checking the A2L status codes (LED) written in the installation manual of "NON A2L FURNACE INTEGRATION KIT".</p>
			<ul style="list-style-type: none"> • Check communication wiring, Repair as needed. <p><Hereafter, when using "NON A2L FURNACE INTEGRATION KIT"></p> <p>*Ventilate the room before conducting any actions as needed.</p> <ul style="list-style-type: none"> • Check refrigerant leakage; Repair as needed. • Check the connection of A2L sensor. • Check the input voltage of A2L sensor (refer to service manual); Replace A2L sensor or control board as needed. <p>*After the above failure is resolved, the error will be restored in about 10 minutes.</p>

7 SEGMENT LED CODES

7 SEGMENT LED DISPLAY	DESCRIPTION OF CONDITION	ERROR MESSAGE
On	Normal Operation	--
EE	EMERGENCY MODE	--
d0	DATA NOT ON NETWORK	Data Not Yet On Network
d4	INVALID MEMORY CARD DATA	Invalid Memory Card data
70	EEV DISCONNECTION DETECTED	EEV OPEN CKT
73	LIQUID SIDE THERMISTOR ABNORMALITY	LIQ TEMP FLT
74	GAS SIDE THERMISTOR ABNORMALITY	GAS TEMP FLT
75	PRESSURE SENSOR ABNORMALITY	PRESSURE FLT
76	CASED COIL - OUTDOOR UNIT, GAS FURNACE OR BLOWER UNIT COMMUNICATION ERROR (DURING OPERATION)	EQUIP COMM LOSS
77	INDOOR UNIT - THERMOSTAT COMMUNICATION ERROR (STARTUP OPERATION & DURING OPERATION)	TSTAT ID NO COM
78	CASED COIL - OUTDOOR UNIT, GAS FURNACE OR BLOWER UNIT COMMUNICATION ERROR (STARTUP OPERATION)	CONNECT EQUIP

SETTING THE MODE DISPLAY

MODE DISPLAY INTRODUCTION

A 2-digit display is provided on the printed circuit board (PCB) as a backup tool to the thermostat for accessing error codes and erasing error code history of the indoor unit. Follow the information provided in this section to learn how to use the mode display

DISPLAY

The display consists of 2 digits.

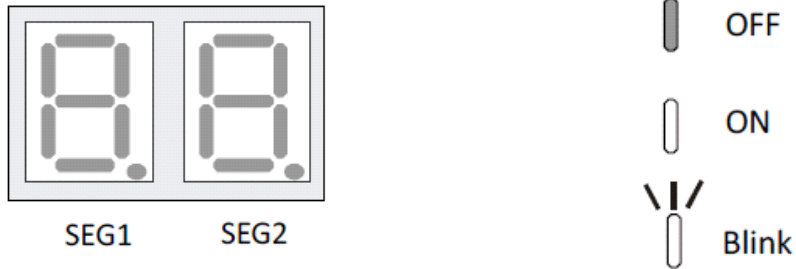

DISPLAY BUTTON LAYOUT

The display buttons shown can be used to navigate and select items:

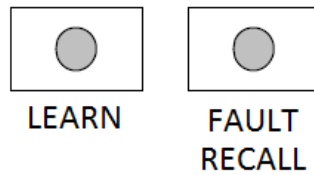

Example of button layout is shown above

FAULT CODE HISTORY NAVIGATION

This mode will allow the user to see the six most recent system faults. Please follow the flow chart to navigate to error codes from screen zero.

For a list of the fault codes, please see the TROUBLESHOOTING tables in this document.

It is also possible to erase all the diagnostics codes from this menu.

TROUBLESHOOTING

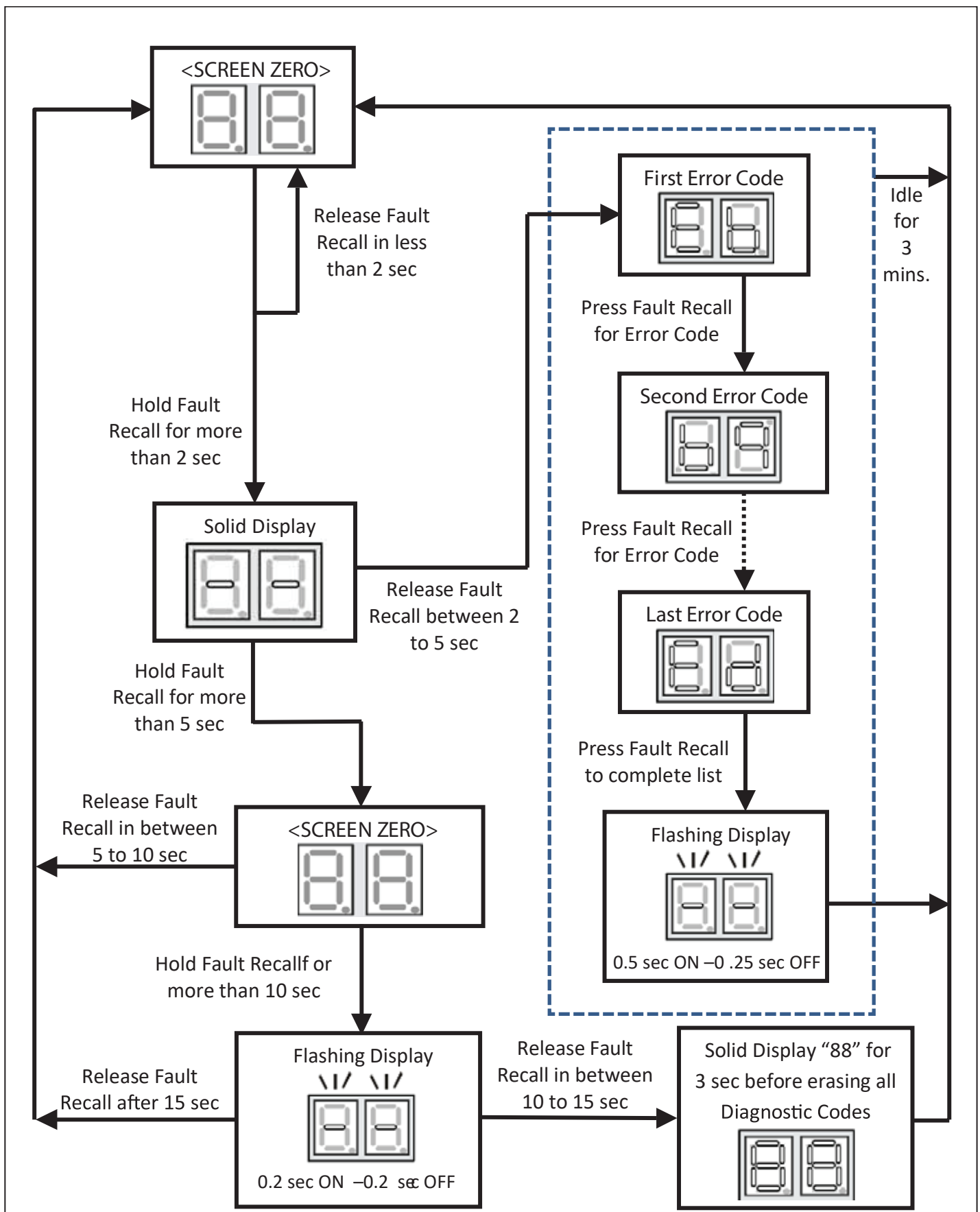

WIRING DIAGRAM



WARNING

HIGH VOLTAGE!
DISCONNECT ALL POWER BEFORE SERVICING OR INSTALLING THIS UNIT.
MULTIPLE POWER SOURCES MAY BE PRESENT. FAILURE TO DO SO MAY
CAUSE PROPERTY DAMAGE, PERSONAL INJURY OR DEATH.



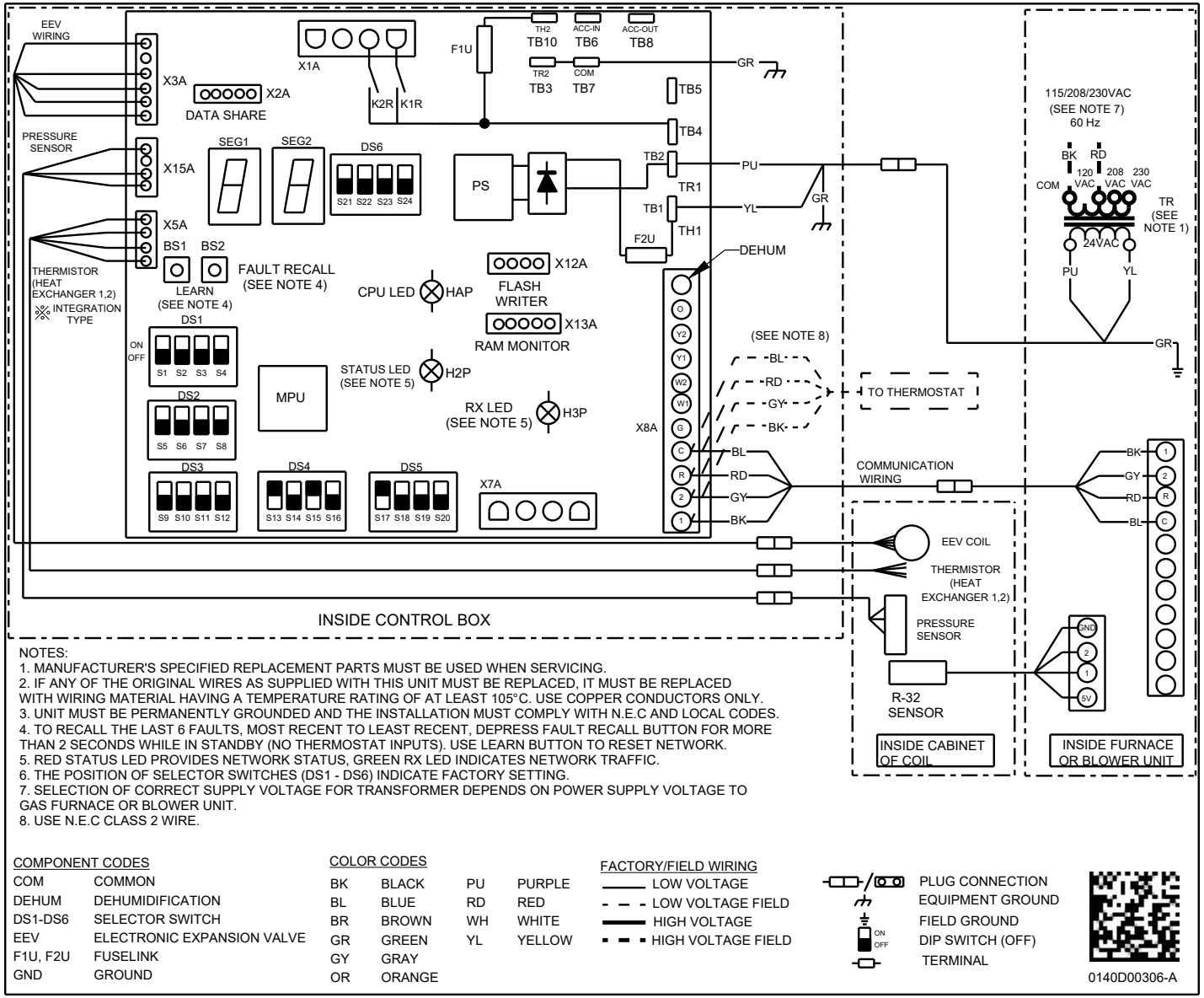

NOTE: THESE INSTRUCTIONS ARE SPECIFICALLY FOR CAPEA MODELS. DO **NOT** ATTEMPT TO APPLY THESE DIAGRAMS TO ANY OTHER MODELS.

CASED COIL

CASED COIL HOMEOWNER'S ROUTINE MAINTENANCE RECOMMENDATIONS

We strongly recommend a bi-annual maintenance checkup be performed before the heating and cooling seasons begin by a **qualified servicer**.

REPLACE OR CLEAN FILTER

IMPORTANT NOTE: Never operate unit without a filter installed as dust and lint will build up on internal parts resulting in loss of efficiency, equipment damage and possible fire.

An indoor air filter must be used with your comfort system. A properly maintained filter will keep the indoor coil of your comfort system clean. A dirty coil could cause poor operation and/or severe equipment damage.



Your air filter or filters could be located in your furnace, in a blower unit, or in "filter grilles" in your ceiling or walls. The installer of your air conditioner or heat pump can tell you where your filter(s) are, and how to clean or replace them.

Check your filter(s) at least once a month. When they are dirty, replace or clean as required. Disposable type filters should be replaced. Reusable type filters may be cleaned.

You may want to ask your dealer about high efficiency filters. High efficiency filters are available in both electronic and non-electronic types. These filters can do a better job of catching small airborne particles.

MOTORS

Indoor and outdoor fan motors are permanently lubricated and do not require additional oiling.

 WARNING	
HIGH VOLTAGE DISCONNECT ALL POWER BEFORE SERVICING OR INSTALLING THIS UNIT. MULTIPLE POWER SOURCES MAY BE PRESENT. FAILURE TO DO SO MAY CAUSE PROPERTY DAMAGE, PERSONAL INJURY OR DEATH.	

ALUMINUM INDOOR COIL CLEANING (QUALIFIED SERVICER ONLY)

R-32 sensor must be removed from the unit before applying coil cleaners to avoid damage and contamination. Reassemble the R-32 sensor back in the unit after completing the coil cleaning process. This unit is equipped with an aluminum tube evaporator coil. The safest way to clean the evaporator coil is to simply flush the coil with water. This cleaning practice remains as the recommended cleaning method for both copper tube and aluminum tube residential evaporator coils.

It has been determined that many coil cleaners and drain pan tablets contain corrosive chemicals that can be harmful to aluminum tube and fin evaporator coils. Even a one-time application of these corrosive chemicals can cause premature aluminum evaporator coil failure. Any cleaners that contain corrosive chemicals including, but not limited to, chlorine and hydroxides, should not be used. An alternate cleaning method is to use one of the products listed in TP-109* to clean the coils. The cleaners listed are the only agents deemed safe and approved for use to clean round tube aluminum coils.

 WARNING
DO NOT USE MEANS TO ACCELERATE THE DEFROSTING PROCESS OR TO CLEAN, OTHER THAN THOSE RECOMMENDED BY THE MANUFACTURER. THE APPLIANCE SHALL BE STORED IN A ROOM WITHOUT CONTINUOUSLY OPERATING IGNITION SOURCES (FOR EXAMPLE: OPEN FLAMES, AN OPERATING GAS APPLIANCE OR AN OPERATING ELECTRIC HEATER). DO NOT PIERCE OR BURN. BE AWARE THAT REFRIGERANTS MAY NOT CONTAIN AN ODOR.

TP-109 is also available on the web site in Partner Link > Service Toolkit.

NOTE: Ensure coils are rinsed well after use of any chemical cleaners.

- Condensate line must be trapped and pitched to allow for drainage.
- Low voltage wiring is properly connected.
- Auxiliary drain is installed when necessary and pitched to allow for drainage.
- Unit is protected from vehicular or other physical damage.
- Return air is not obtained from, nor are there any return air duct joints that are unsealed in, areas where there may be objectionable odors, flammable vapors or products of combustion such as carbon monoxide (CO), which may cause serious personal injury or death.
- Ensure that the equipped R-32 sensor is wired to the furnace PCB and that there are no sources of potential ignition within the system.

 CAUTION
TO AVOID THE RISK OF EQUIPMENT DAMAGE OR FIRE, INSTALL THE SAME AMPERAGE BREAKER OR FUSE AS YOU ARE REPLACING. IF THE CIRCUIT BREAKER OR FUSE SHOULD OPEN AGAIN WITHIN THIRTY DAYS, CONTACT A QUALIFIED SERVICER TO CORRECT THE PROBLEM. IF YOU REPEATEDLY RESET THE BREAKER OR REPLACE THE FUSE WITHOUT HAVING THE PROBLEM CORRECTED, YOU RUN THE RISK OF SEVERE EQUIPMENT DAMAGE.

BEFORE YOU CALL YOUR SERVICER

- Check the thermostat to confirm that it is properly set.
- Wait 15 minutes. Some devices in the outdoor unit or in programmable thermostats will prevent compressor operation for awhile, and then reset automatically. Also, some power companies will install devices which shut off air conditioners for several minutes on hot days. If you wait several minutes, the unit may begin operation on its own.
- Check the electrical panel for tripped circuit breakers or open fuses. Reset the circuit breakers or replace fuses as necessary.
- Check the disconnect switch near the indoor furnace or blower to confirm that it is closed.
- Check for obstructions on the outdoor unit. Confirm that it has not been covered on the sides or the top. Remove any obstruction that can be safely removed. If the unit is covered with dirt or debris, call a qualified servicer to clean it.
- Check for blockage of the indoor air inlets and outlets. Confirm that they are open and have not been blocked by objects (rugs, curtains or furniture).
- Check the filter. If it is dirty, clean or replace it.
- Listen for any unusual noise(s), other than normal operating noise, that might be coming from the outdoor unit. If you hear unusual noise(s) coming from the unit, call a qualified servicer.

REFRIGERANT RECOVERY

When removing refrigerant from a system, either for servicing or decommissioning, it is recommended good practice that all refrigerants are removed safely. When transferring refrigerant recovery cylinders, ensure that only appropriate refrigerant recovery cylinders are employed. Ensure that the correct number of cylinders for holding the total system charge are available. All cylinders to be used are designated for the recovered refrigerant and labeled for that refrigerant (i.e. special cylinders for the recovery of refrigerant). Cylinders shall be complete with pressure-relief valve and associated shut-off valves in good working order. Empty recovery cylinders are evacuated and, if possible, cooled before recovery occurs.

The recovery equipment shall be in good working order with a set of instructions concerning the equipment that is at hand and shall be suitable for the recovery of the flammable refrigerant. If in doubt, the manufacturer should be consulted. In addition, a set of calibrated weighting scales shall be available and in good working order. Hoses shall be complete with leak-free disconnect couplings and in good condition. The recovered refrigerant shall be processed according to local legislation in the correct recovery cylinder, and the relevant waste transfer note arranged. Do not mix refrigerants in recovery units and especially not in cylinders.

If compressors or compressor oils are to be removed, ensure that they have been evacuated to an acceptable level to make certain that flammable refrigerant does not remain within the lubricant. The compressor body shall not be heated by an open flame or other ignition sources to accelerated this process. When oil is drained from a system, it shall be carried out safely.

START-UP CHECKLIST

Air Handler / Coil			
	Model Number	_____	
	Serial Number	_____	
ELECTRICAL			
Line Voltage (Measure L1 and L2 Voltage)	L1 - L2	_____	
Secondary Voltage (Measure Transformer Output Voltage)	R - C	_____	
Blower Amps		_____	
Heat Strip 1 - Amps		_____	
Heat Strip 2 - Amps		_____	
BLOWER EXTERNAL STATIC PRESSURE			
Return Air Static Pressure		_____	IN. W.C.
Supply Air Static Pressure		_____	IN. W.C.
Total External Static Pressure (Ignoring +/- from the reading above, add total here)		_____	IN. W.C.
TEMPERATURES			
Return Air Temperature (Dry bulb / Wet bulb)		_____ DB °F	_____ WB °F
Cooling Supply Air Temperature (Dry bulb / Wet bulb)		_____ DB °F	_____ WB °F
Heating Supply Air Temperature		_____ DB °F	
Temperature Rise		_____ DB °F	
Delta T (Difference between Supply and Return Temperatures)		_____ DB °F	
Air Handler / Coil - (Inverter Matched)			
INVERTER AH / COIL ONLY			
Check EEV and EEV wiring is secure (no adjustment required)		_____	
Additional Checks			
Check wire routings for any rubbing		_____	
Check product for proper draining		_____	
Check screw tightness on blower wheel		_____	
Check factory wiring and wire connections		_____	
Check product for proper clearances as noted by installation instructions		_____	
Check R-32 sensor wiring & wire connections to the corresponding furnace or Non-A2L integration boards		_____	
Check that mitigation mode is operational		_____	
°F to °C formula: (°F - 32) divided by 1.8 = °C °C to °F formula: (°C multiplied by 1.8) + 32 = °F			

CUSTOMER FEEDBACK

We are very interested in all product comments.

Please fill out the feedback form on one of the following links:

Daikin Products: (<https://daikincomfort.com/contact-us>)

Goodman® Brand Products: (<http://www.goodmanmfg.com/about/contact-us>).

Amana® Brand Products: (<http://www.amana-hac.com/about-us/contact-us>).

You can also scan the QR code on the right for the product brand you purchased to be directed to the feedback page.



DAIKIN



GOODMAN® BRAND



AMANA® BRAND

NOTE: SPECIFICATIONS AND PERFORMANCE DATA LISTED HEREIN ARE SUBJECT TO CHANGE WITHOUT NOTICE

Quality Makes the Difference!

All of our systems are designed and manufactured with the same high quality standards regardless of size or efficiency. We have designed these units to significantly reduce the most frequent causes of product failure. They are simple to service and forgiving to operate. We use quality materials and components. Finally, every unit is run tested before it leaves the factory.

That's why we know. . . **There's No Better Quality.**

Our continuing commitment to quality products may mean a change in specifications without notice.

© 2024 **DAIKIN COMFORT TECHNOLOGIES MANUFACTURING, L.P.**

19001 Kermier Rd., Waller, TX 77484

www.daikincomfort.com • www.goodmanmfg.com • www.amana-hac.com

Amana is a registered trademark of Maytag Corporation or its related companies and is used under license. All rights reserved.